

CONSTRUCTION, ARCHITECTURE AND ENGINEERING

CONSTRUCTION, ARCHITECTURE AND ENGINEERING

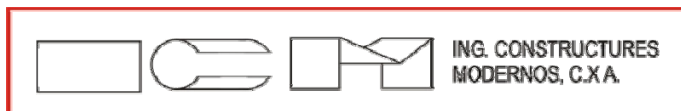

ARQUITECTOS-INGENIEROS-CONTRATISTAS

**Address:** Max Henríquez Ureña No.33  
Edificio KIRA, 4to. Piso  
Santo Domingo, Rep. Dom.

**Telephone:** 562-6900 Fax: 544-3505  
**E-mail:** [icm.cxa@codetel.net.do](mailto:icm.cxa@codetel.net.do)



---

ESTE DOCUMENTO ES PROPIEDAD DE:  
**“INGENIEROS CONSTRUCTORES MODERNOS”**  
QUIEN TIENE TODOS LOS DERECHOS RESERVADOS DEL MISMO  
Y NO DEBERA SER COPIADO, FOTOCOPIADO, TRADUCIDO O REPRODUCIDO  
MEDIANTE CUALQUIER MEDIO ELECTRONICO O POR OTROS METODOS  
SIN EL CONSENTIMIENTO PREVIO POR ESCRITO DE LA EMPRESA



ING. CONSTRUCTORES  
MODERNOS, C.X.A.

ARQUITECTOS-INGENIEROS-CONTRATISTAS

## COMPANY INFO



**Dirección:** Max Henríquez Ureña No.33  
Edificio KIRA, 4to. Piso  
Santo Domingo, Rep. Dom.

**Teléfonos:** 562-6900 fax: 544-3505  
**Dirección electrónica:** [icm.cxa@codetel.net.do](mailto:icm.cxa@codetel.net.do)

## TABLE OF CONTENTS

- A. Corporate Profile
- B. Organization Chart
- C. Professional References
- D. Projects



## Corporate Profile

ICM is a group of prominent architects and engineers with a visionary multidisciplinary partnership.

Since April of 1984 we can offer our clients a complete range of integrated products and services; including the design, engineering, and construction of industrial, residential and commercial projects.

This capacity allows us to become a more integral part of our client's needs and expectations.

ICM stands out, because of its innovative policy with modern technology; offering practical and innovative solutions as a result from the combination of the design and engineering capabilities of our draftsmen and the utilization of computer-assisted design and fabrication techniques.

Our experience enables us to establish alliances with international firms, expanding into new economies, forming strategic relationships that will enable us to continue exploring new opportunities worldwide.



## What We Do

- Commercial
- Consulting
- Industrial
- Infrastructure
- Institutional
- Process Engineering
- Project Management
- Residential
- Services During Construction
- Urban Planning

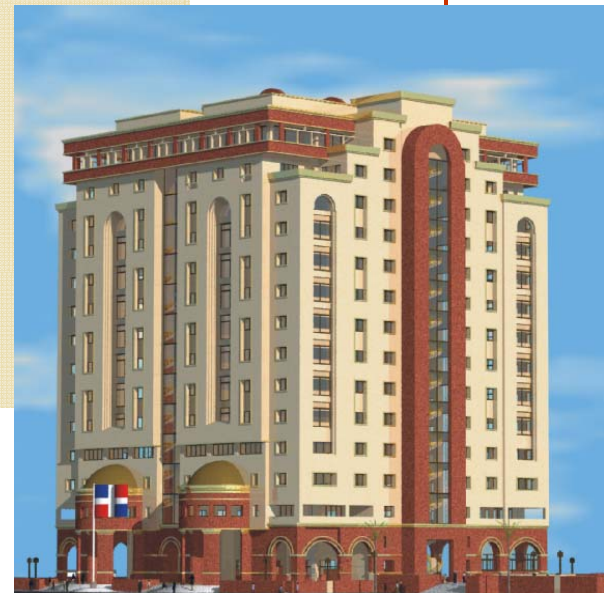
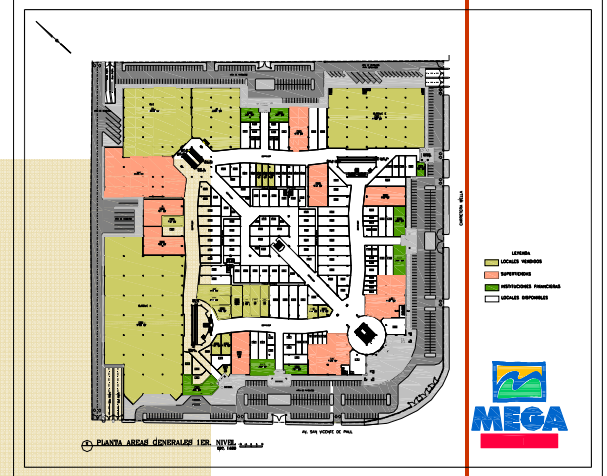

# ORGANIZATIONAL CHART

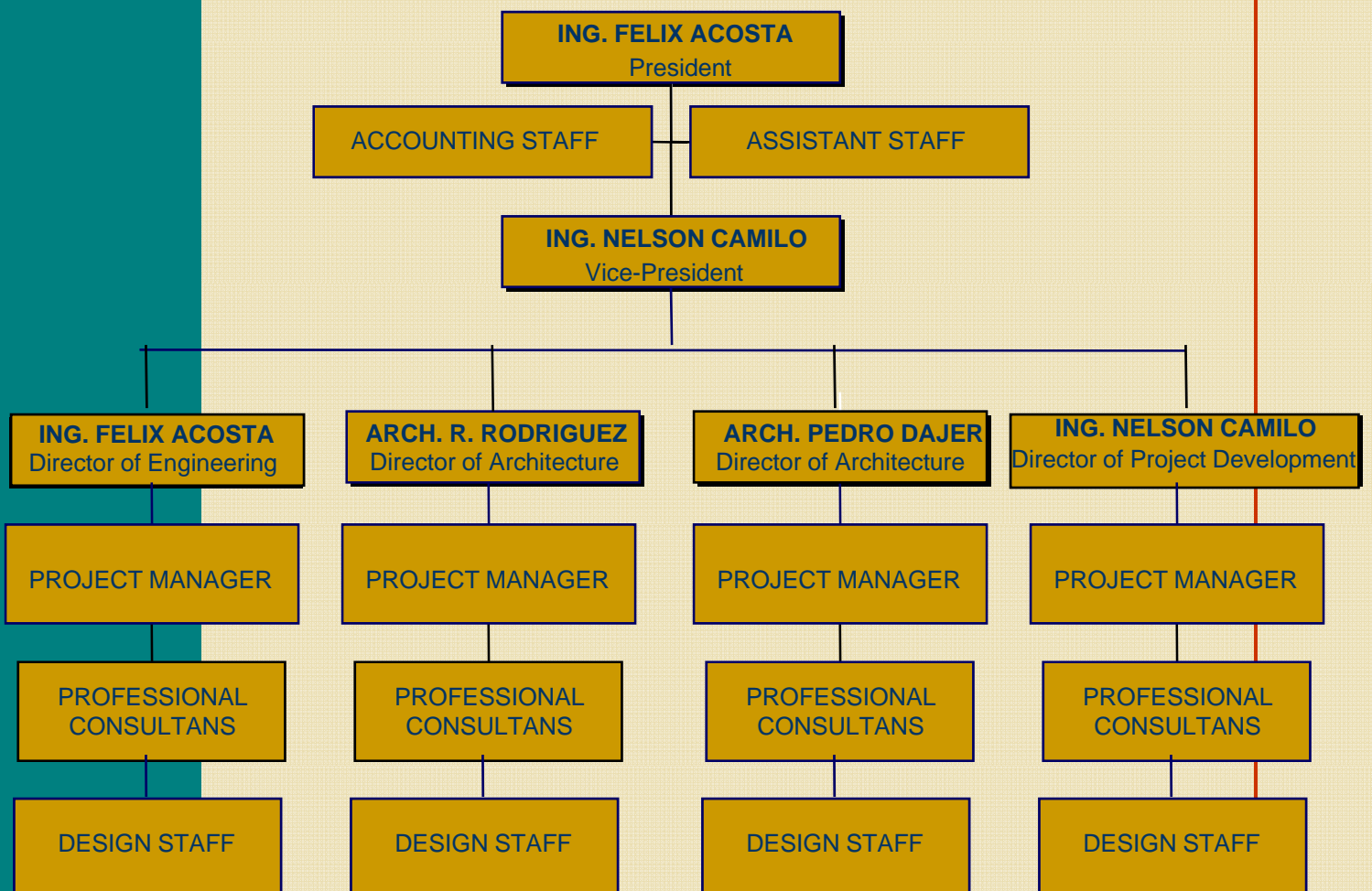

## PROFESSIONAL REFERENCES

### Ing. Felix Acosta

President

As President and Director of Engineering, Acosta provided over twenty years of leadership in the administration and management of a variety of building construction project nationwide. He has overall responsibility for corporate administration, finance, bonding, marketing, and business development, in addition to ultimate responsibility for customer satisfaction.

### Ing. Nelson Camilo

Vice-President

Camilo has over twenty five years of practical experience in all phases of construction techniques. He is responsible for all design and engineering disciplines, in addition to the direction of project development activities.

As the project director he provides liaison between the owner and all personnel of ICM.

### Arch. Rafael Rodriguez

And Pedro Dajer

Directors of Architecture

They both have more than twenty years of architectural experience in diversified Residential, Commercial and Institutional Projects. They are responsible for architectural design, space planning, programming, and the supervision of the architectural designers and draftsmen.

### Ing. David Camilo

Project Manager

The project manager is responsible for the project estimating and scheduling, material procurement, subcontractor coordination and to ensure project progress is consistent with the client's requirements.

### Design Staff

All personnel of drafting and design staff have ten years of experience in all phases of residential, commercial, and Industrial projects, including office buildings, retail shopping centers, automobile dealerships and ocean front condominiums and houses.



# PROJECTS

## INDUSTRIAL

ICM's vast expertise in the industrial field has helped promote our country's development.

We use only the latest technology in meeting the specific requirement for each project.

In doing so, we have provided time tested designs that withstand decades of use.

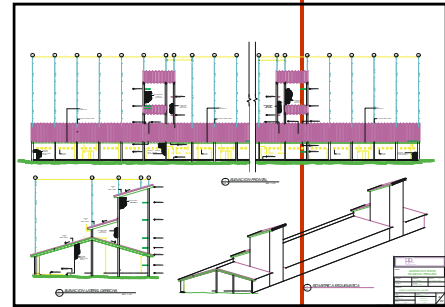
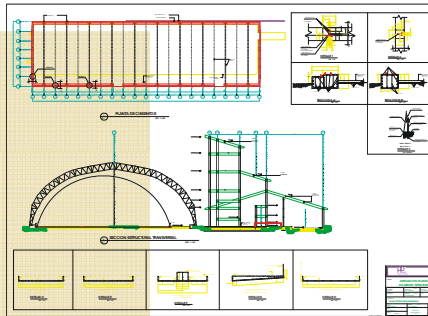

## URBAN PLANNING

ICM is looking ahead at what's in store for urban planning. ICM carefully studies the project, making sure that all-clients and public realm- are fully satisfied.

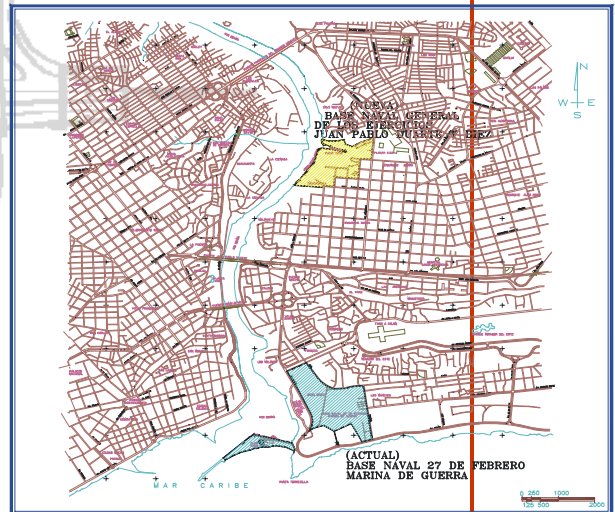
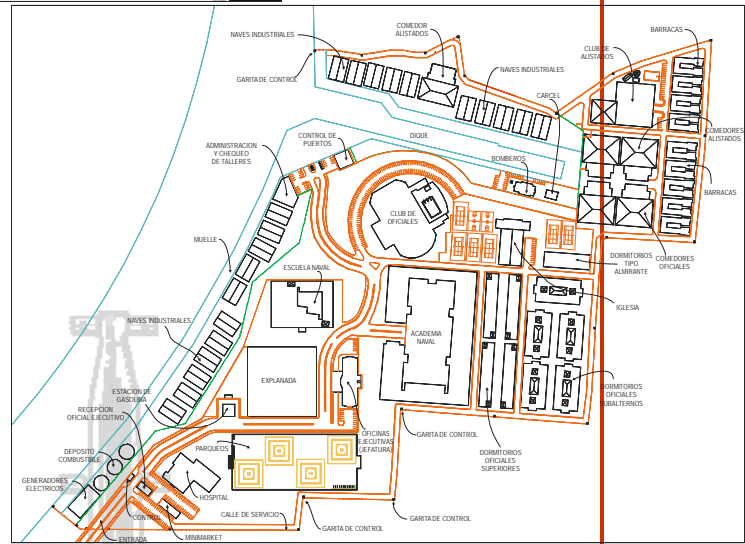

**UBICACION**

# PROJECTS

## RESIDENTIAL

Be it a condominium or a housing development, ICM's design fits changing lifestyles, thus contributing to the improvement of overall quality of life.



## COMERCIAL

An office, a warehouse or a resort, ICM takes on diverse projects, broadening its expertise and establishing design landmarks throughout the island.



## INSTITUTIONAL

Through its vast design tradition, ICM has made valuable contributions in the realm of institutional projects; be it a hospital, a school, charity or other, we at ICM have contributed in the improvement of our island.

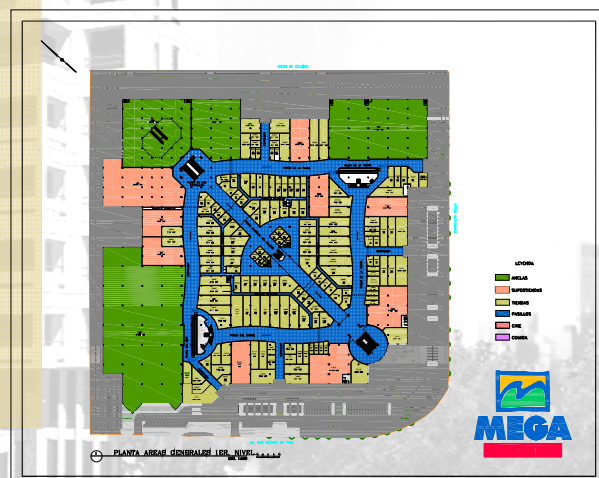

# PROJECTS

## INFRASTRUCTURE

With a long list of public works to our credit, we at ICM have helped provide the island with solid basis for its growth.

In the past two decades we have designed a large number of bridges and highways that have linked remote corners of the island.

Our transportation studies have given way to innovative ideas further shortening distances, such as the application of advanced technology.

Our participation in a variety of projects has not only contributed to expanding the economy, but to modernizing the island and improving the public's health and welfare.

## PROJECTS MANAGEMENT

ICM's project management experience allow us to effectively allot resources to match design objectives, schedule and budget.

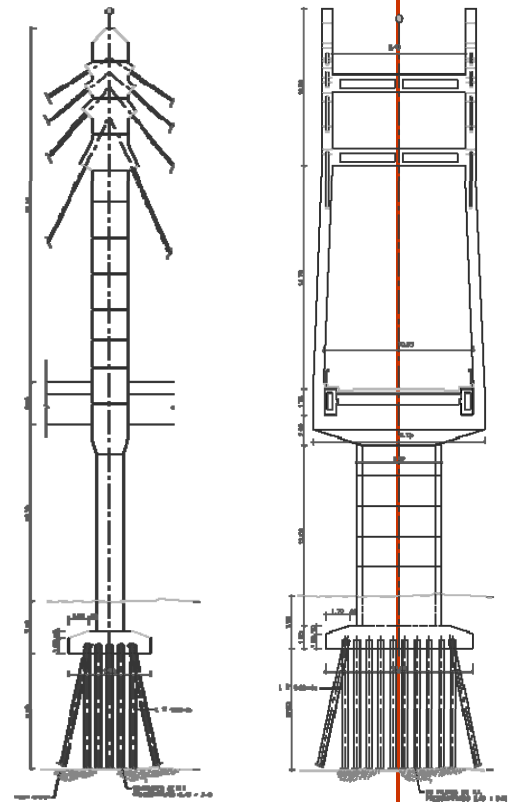
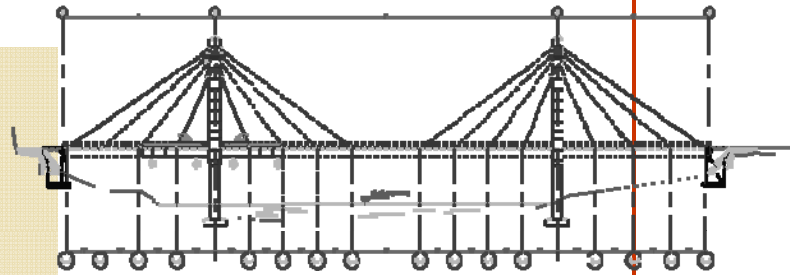

# PROJECTS

## SERVICES DURING CONSTRUCTION

During project constructions, ICM evaluates materials and methods, construction cost and project budget and verifies that the construction complies fully with drawings and specifications.

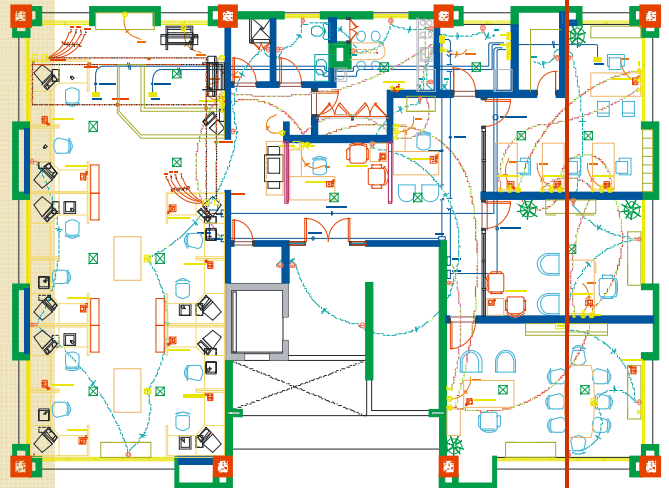

## CONSULTING

ICM's vast experience has assisted local and international firms in the development of specific task, be it resort complex, airport facility or infrastructure projects.

We have acting to successful completion of project acting as consultants to other professionals.

We also offer our clients a broad range of consulting services, such as programming, planning, land use planning, scheduling, cost estimates, permitting and value engineering, among others.

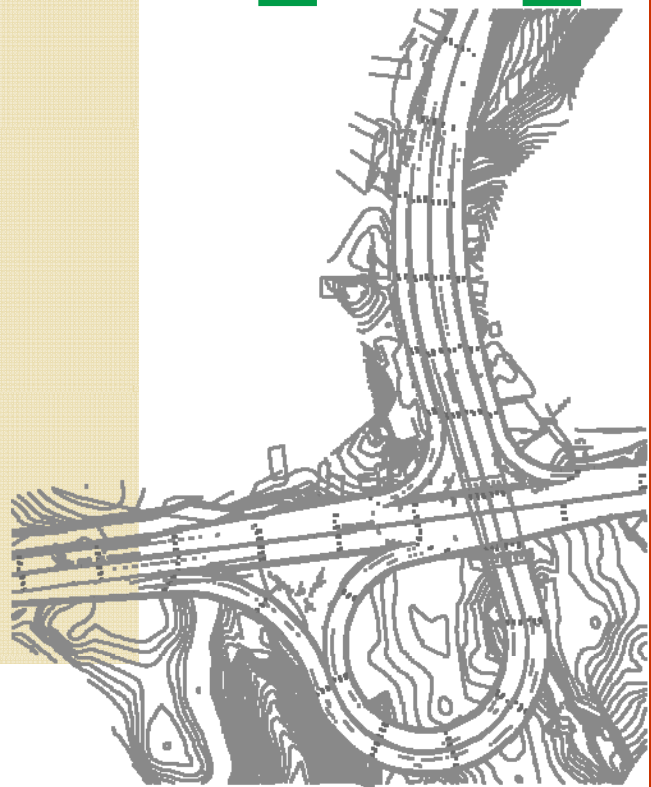

## MAIN INFO

- **Name or Trade name:** I.C.M. Ingenieros Constructores Modernos
- **Main address:** Max Henríquez Ureña No.33  
Edificio KIRA, 4to. Piso  
Santo Domingo, República Dominicana
- **Post-office box:** 20131
- **Telephone:** 809-562-6900
- **Fax:** 809-544-3505
- **E-mail:** icm.cxa@codetel.net.do
- **Legal representative:** Ingeniero Félix Acosta Espinosa (*President*)  
Ingeniero Nelson Camilo (*Vice-President*)



# Residential Portfolio

Selected Project

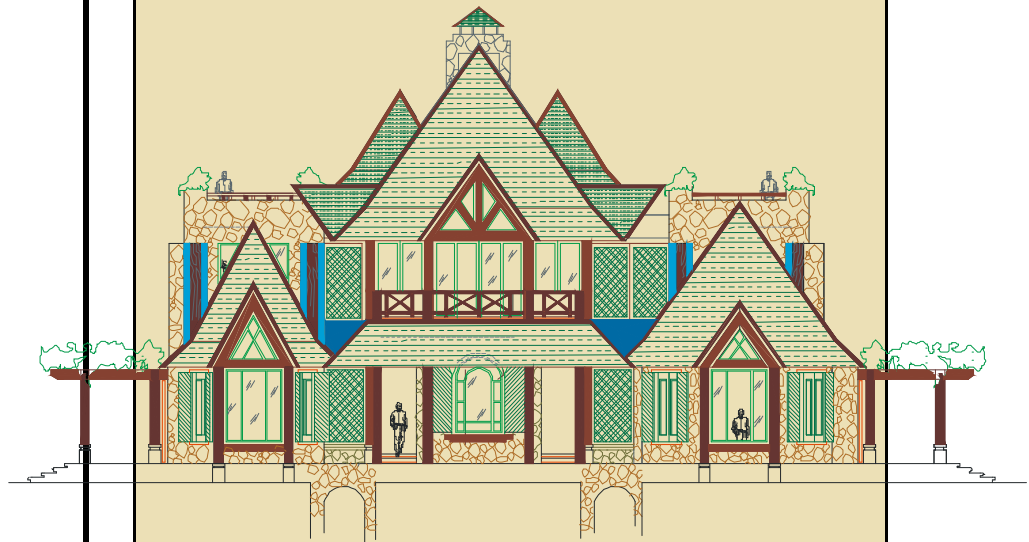
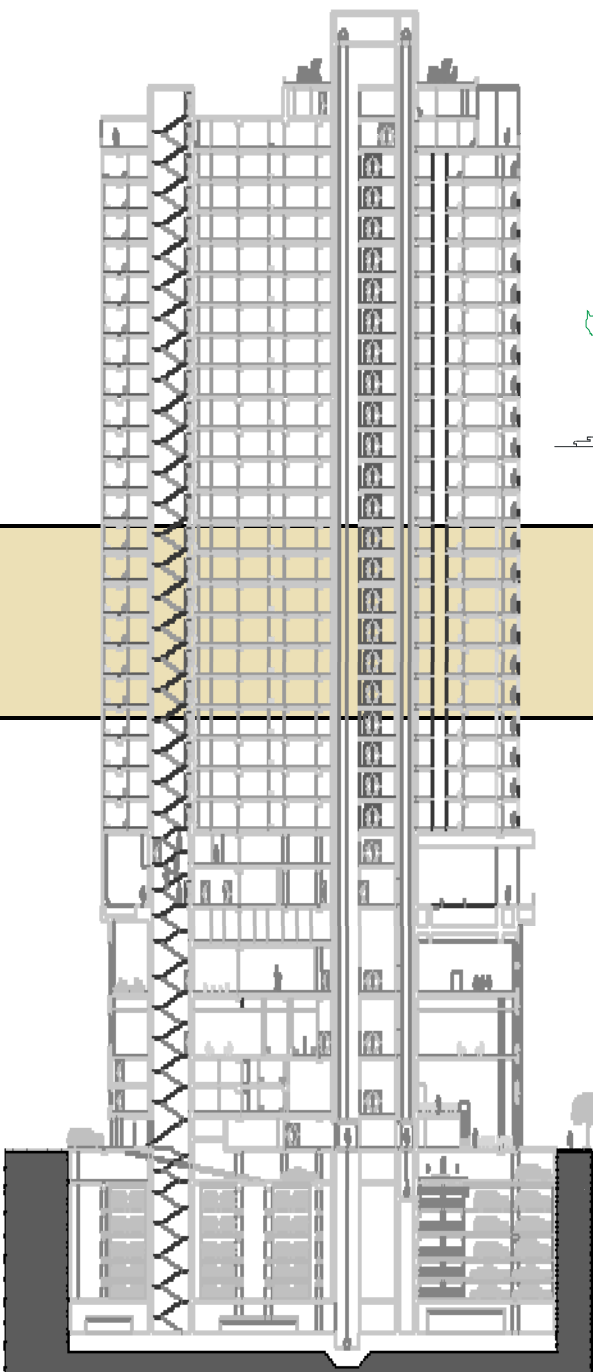

ARQUITECTOS-INGENIEROS-CONTRATISTAS

# The Metropolitan (Formerly Condor Tower)

Location: Sarasota Avenue  
Santo Domingo

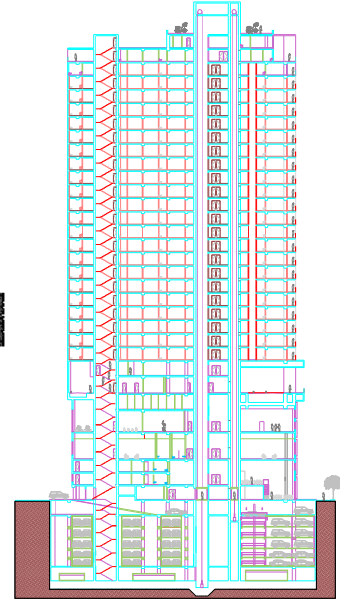
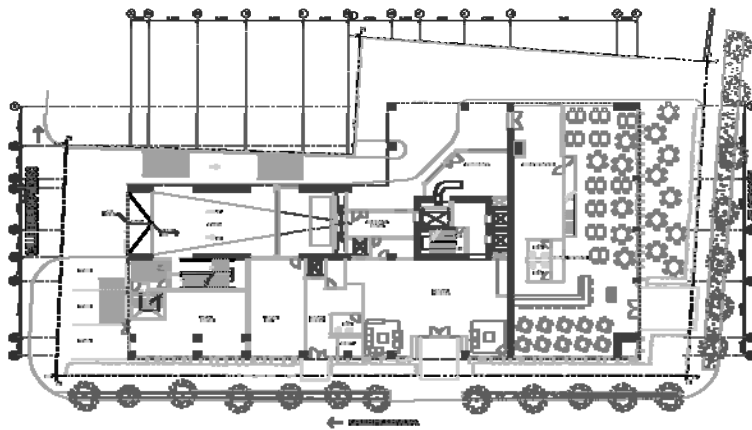

# Casa Isla

Location : Cumayasa  
San Pedro de Macoris

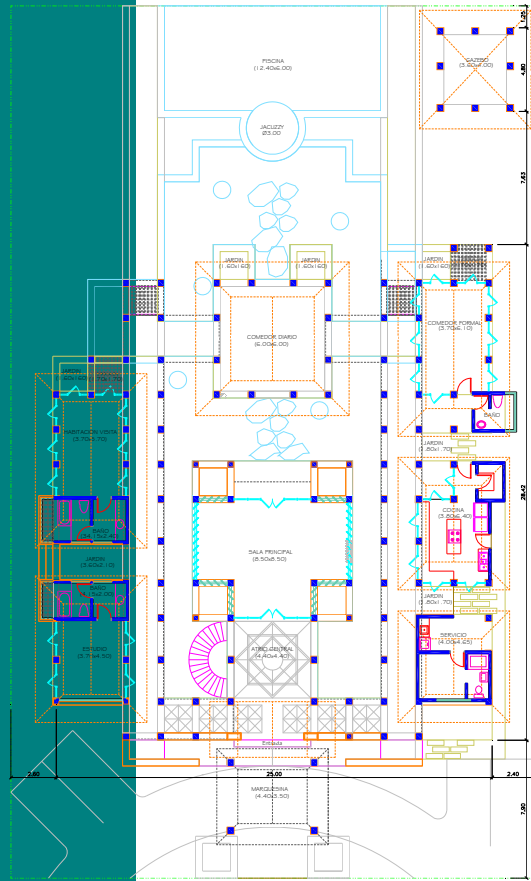

PLANTA ARQUITECTONICA 1ER. NIVEL  
ESC. 1:100

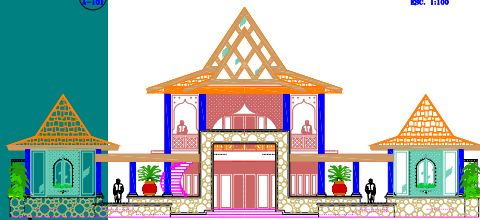

ELEVACION FRONTAL  
ESC. 1:100

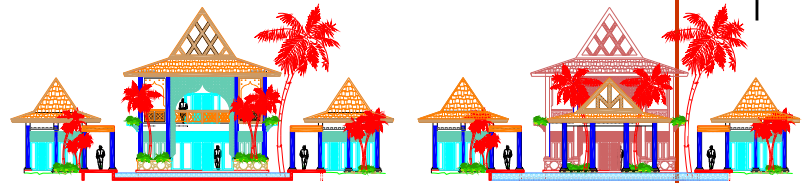

ELEVACION POSTERIOR (SIN COMEDOR)

ELEVACION POSTERIOR (CON COMEDOR)

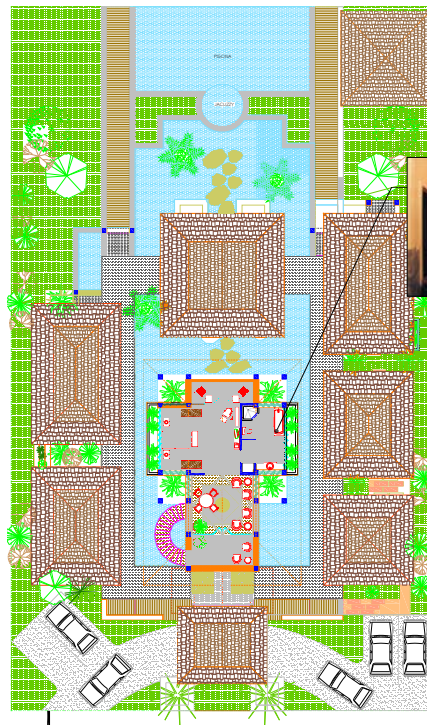

PLANTA ARQUITECTONICA SEGUNDO NIVEL



PANEL DE MADERA

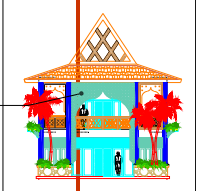

ELEVACION FRONTAL



# Orchid Bay

Location : Bavaro

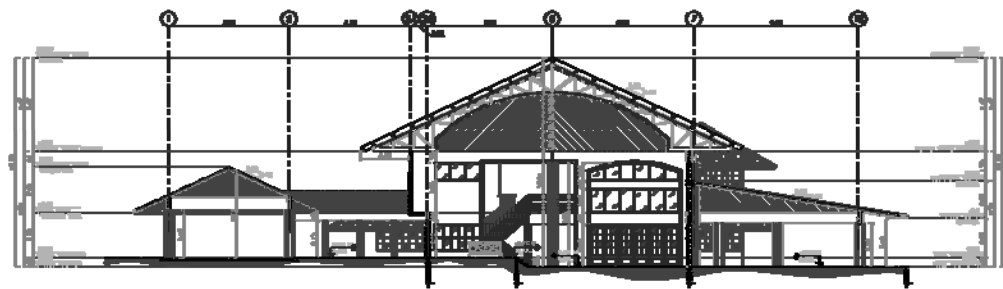

SECCION LONGITUDINAL

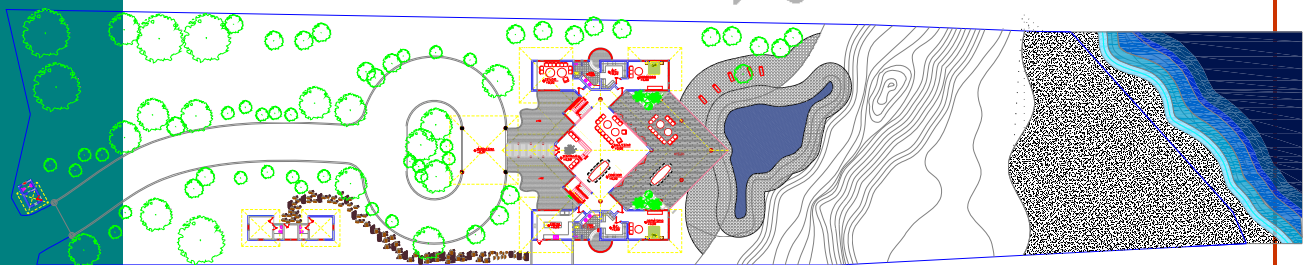
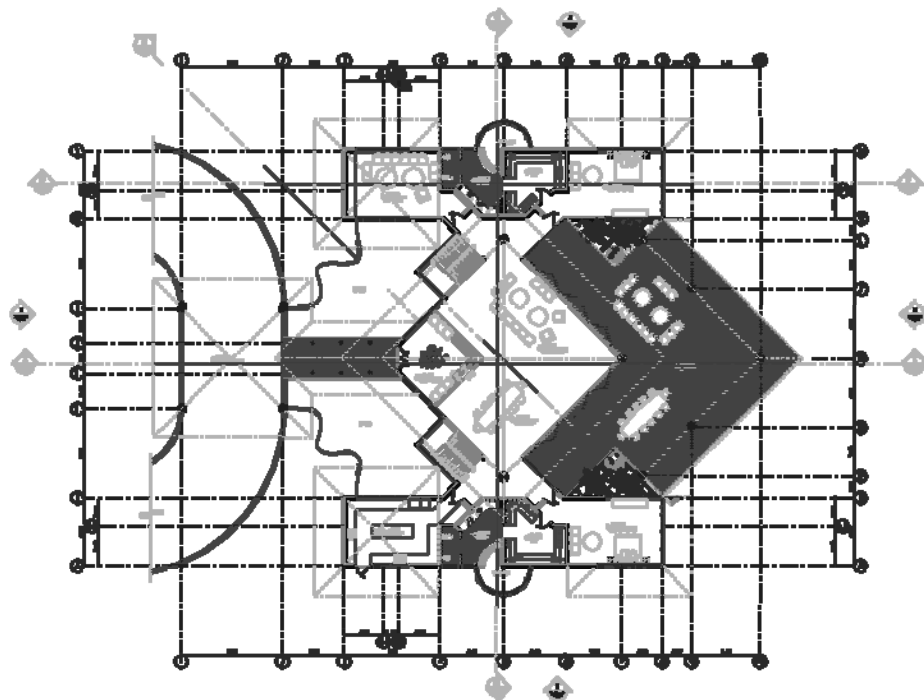

# Urb. Fernandez

Location : Las Lomas  
Santiago

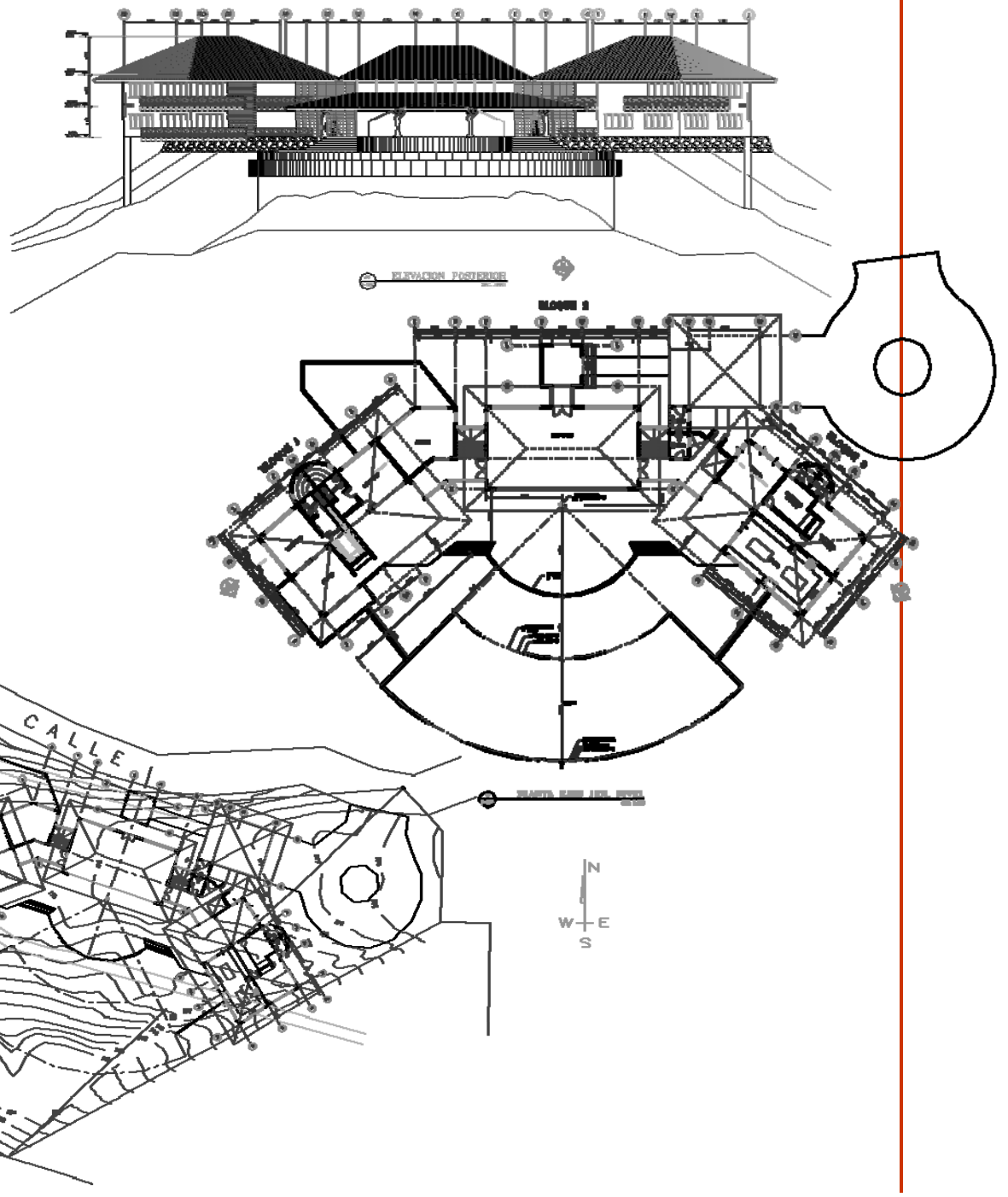

# Res. Las Acacias

Location : Casa Campo  
Romana

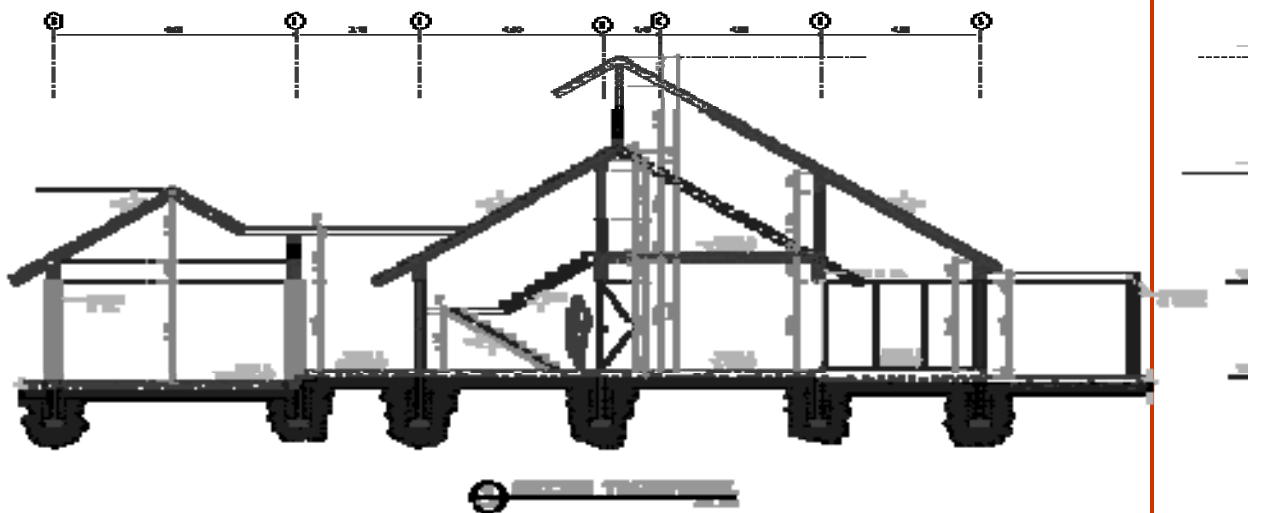
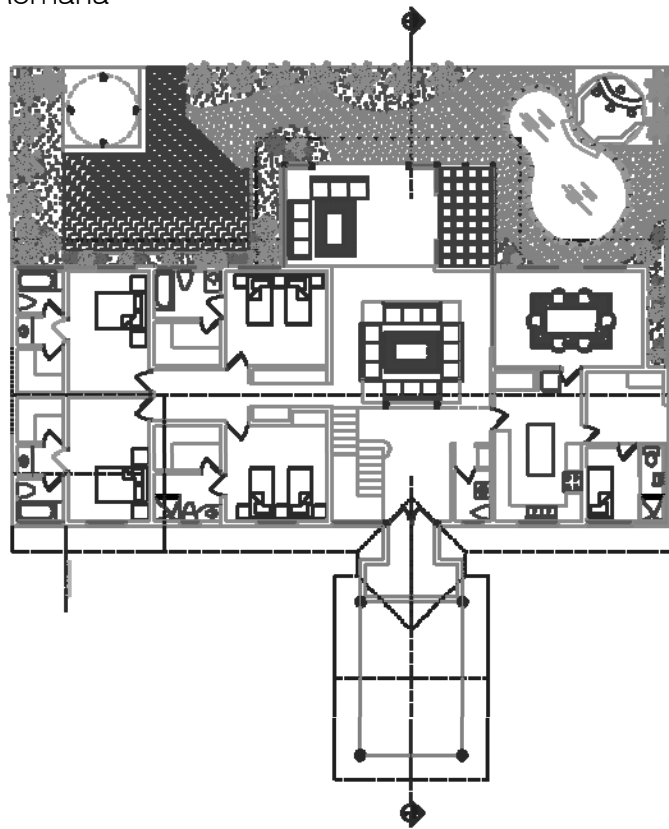

# Res. Ocoa

Location : Palmar de Ocoa  
 San Jose de Ocoa

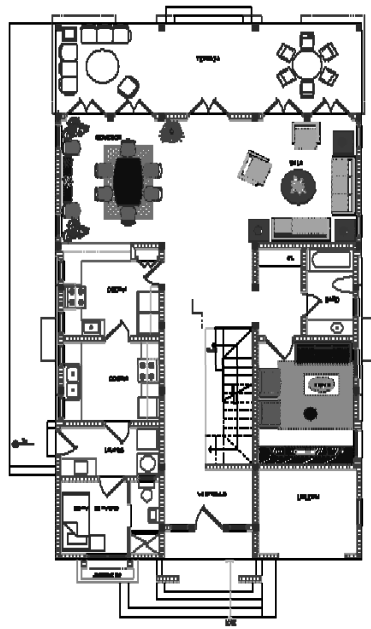

 PLANTA AMUEBLADA PRIMER NIVEL  
 200 1:200

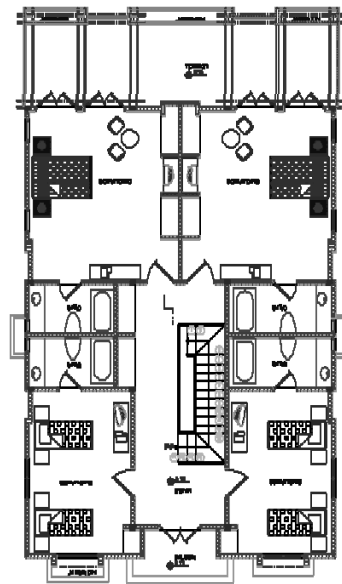

 PLANTA AMUEBLADA SEGUNDO NIVEL  
 200 1:200

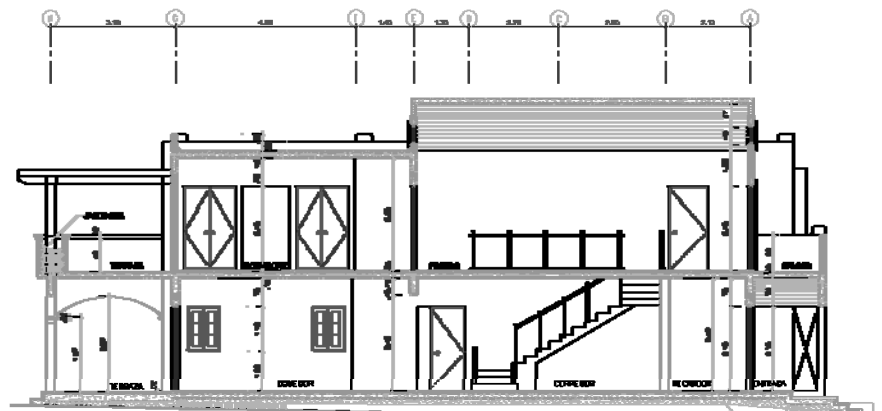



 SECCION LONGITUDINAL  
 200 1:400

RELEVO  
 CERRAMIENTO  
 TORNOJO  
 MUEBLA

# Res. Barranca

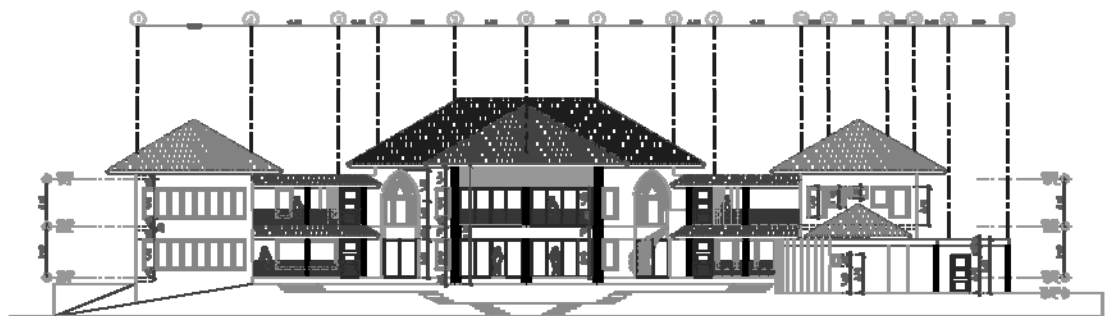
Location : Casa de campo  
Romana



ELEVACION POSTERIOR

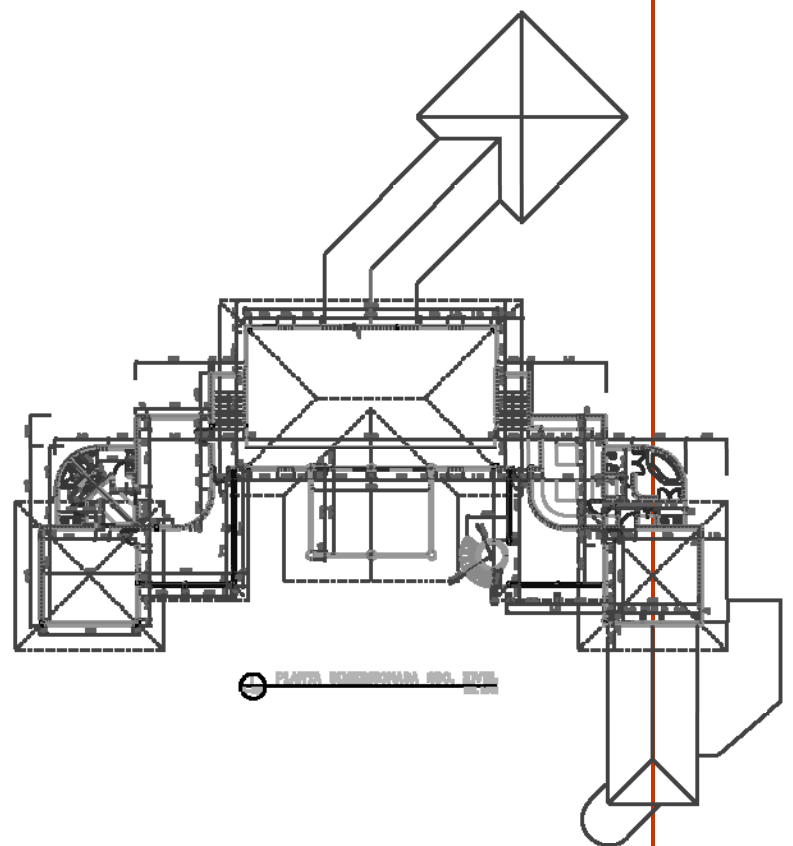
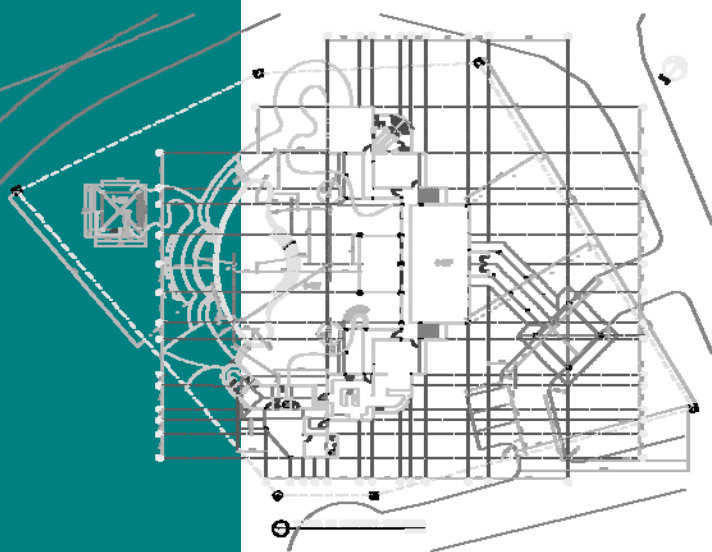

PLANO GENERAL DEL PISO

# Res. Barranca Este

Location : Casa de Campo  
Romana

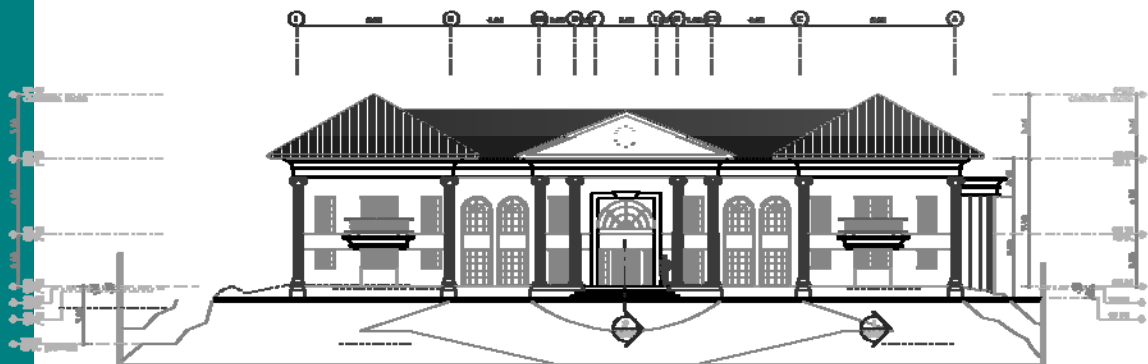

ELEVACION FRONTAL  
02/10/18

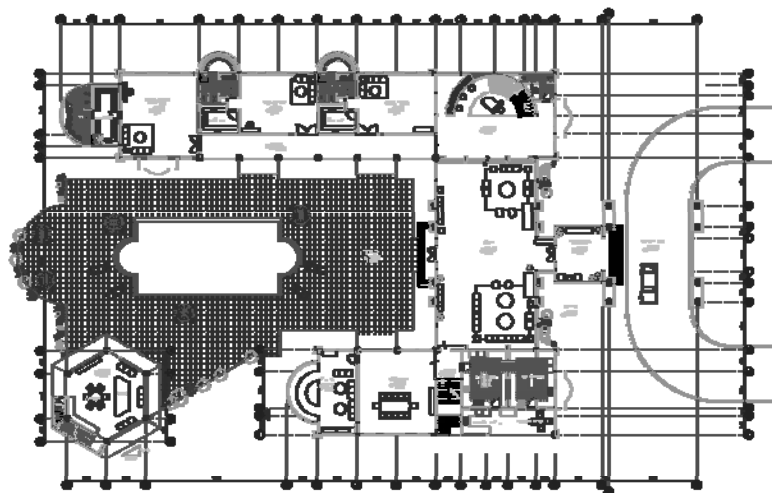

PLANO DE TIPOLOGIA  
02/10/18

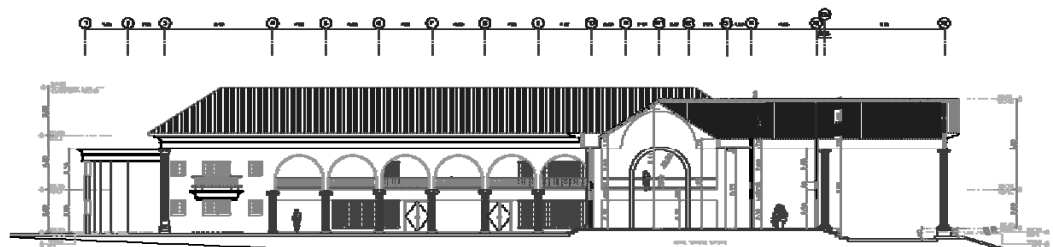

ELEVACION LATERAL  
02/10/18

# Res. Rodriguez

Location : Punta Village  
Punta Cana

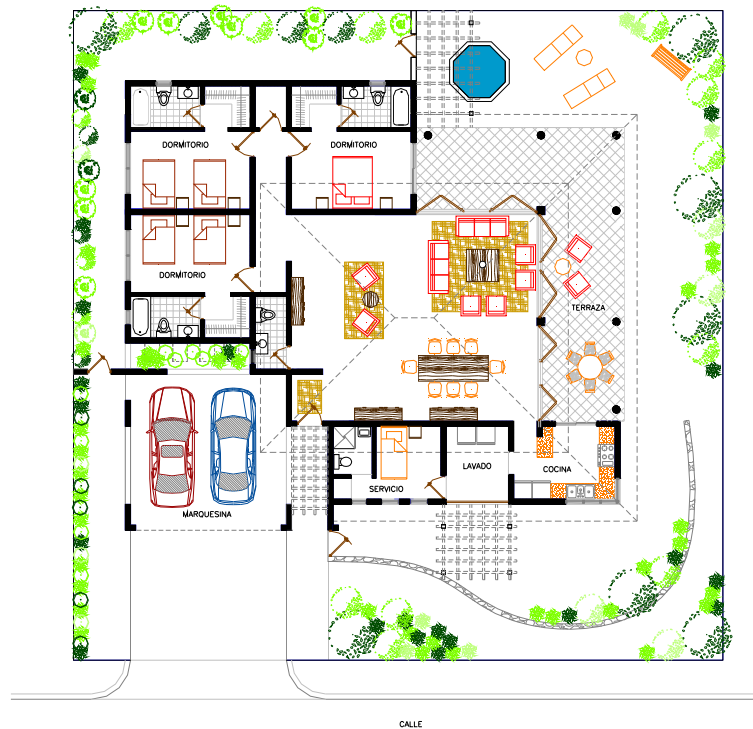

A1  
A-101
**PLANTA ARQUITECTONICA**  
 ESC. 1:125



A1  
A-102
**ELEVACION FRONTAL**  
 ESC. 1:100

# Res. Las Trinitarias

Location : Cuesta Hermosa III  
Arroyo Hondo

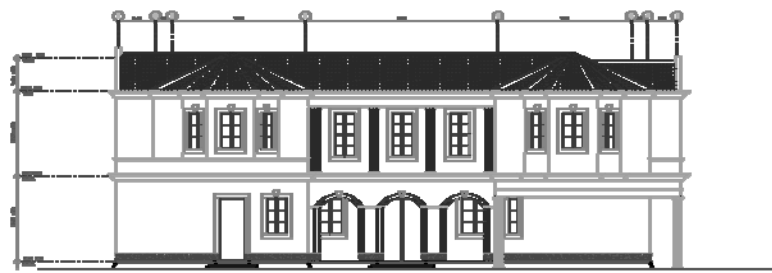
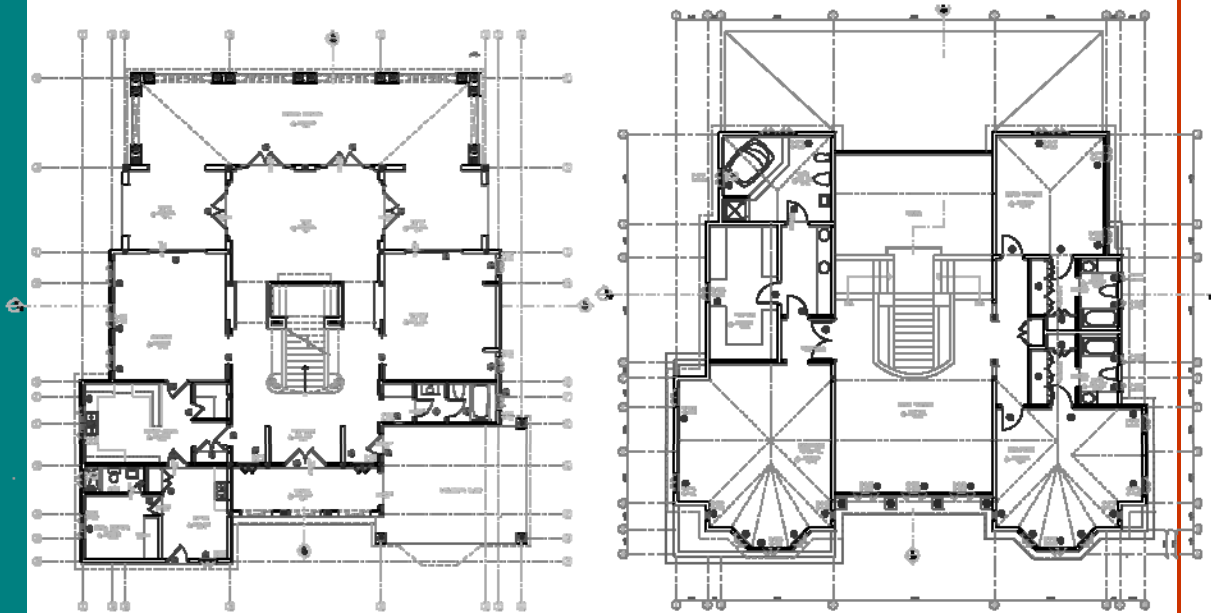

FRONTE PRINCIPAL

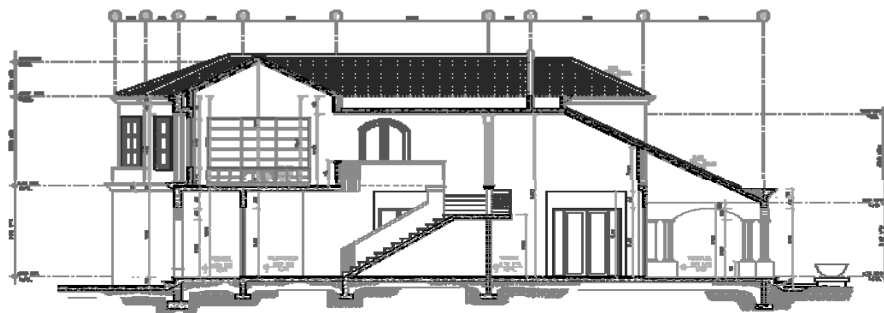

FRONTE LATERAL A-A



# Res. Las Cayenas

Location : Cuesta Hermosa

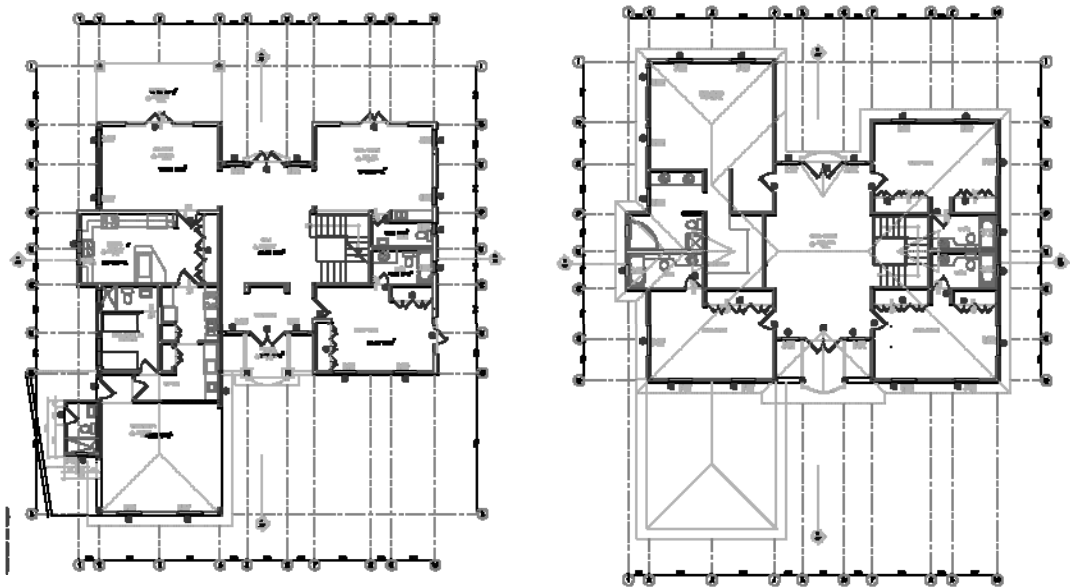

# Res. Rancho Arriba

Location : Casa de Campo  
Romana

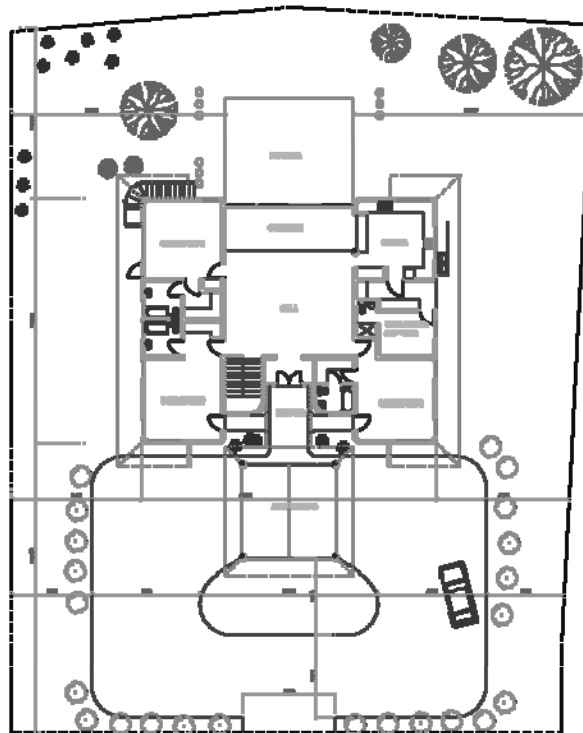

PLANTA UBICACION  
AR-04

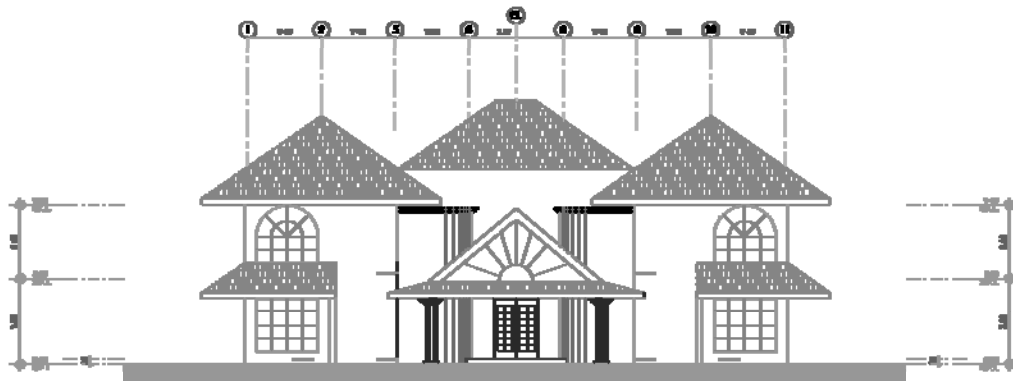

ELEVACION FRONTAL  
AR-04 ESC. 1/70

# Res. Vista del Mar

Location : Casa de Campo Romana

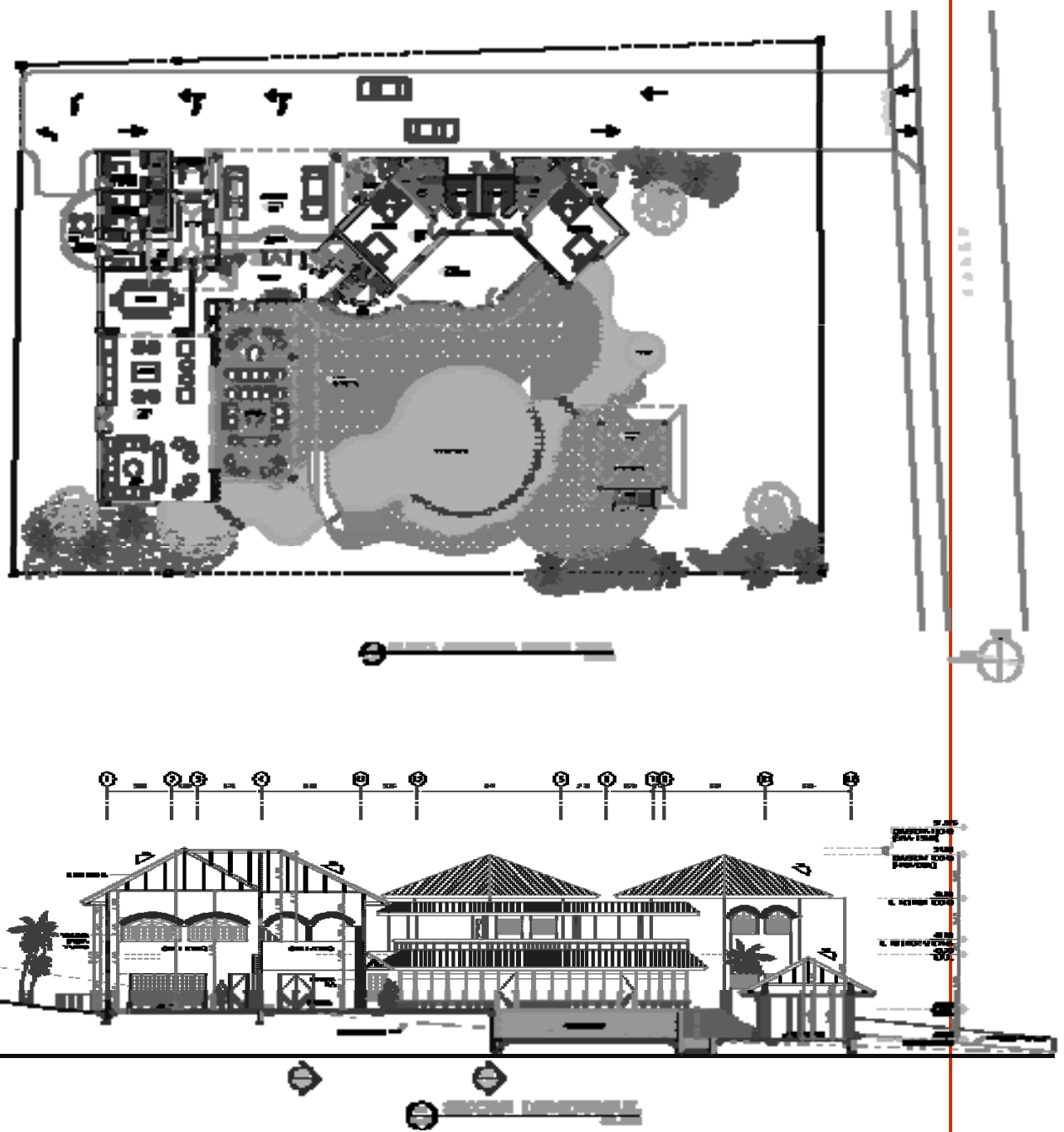

# Res. Vista del Mar

Location : Romana

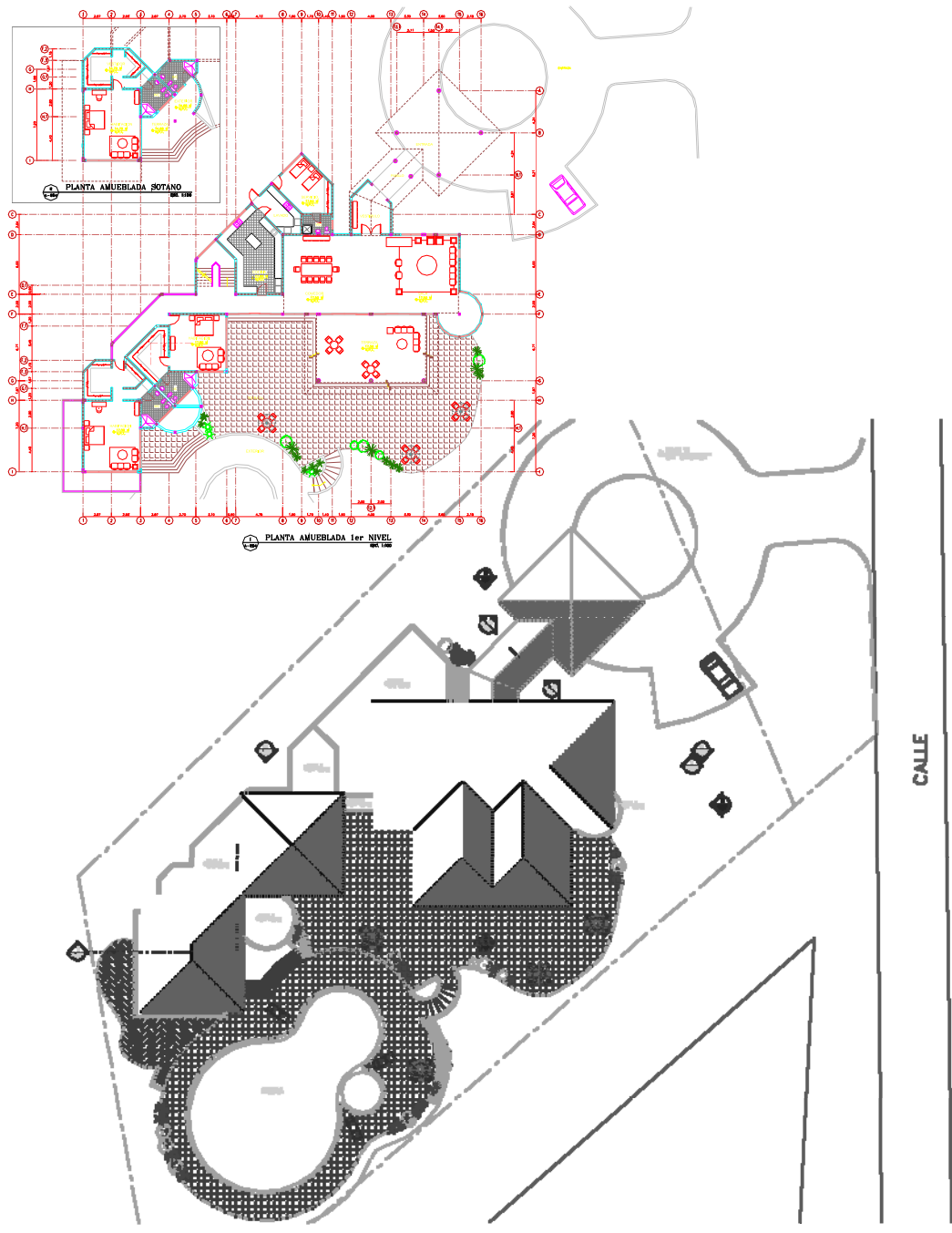



# Commercial Portfolio

Selected Project

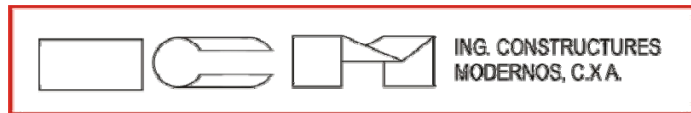
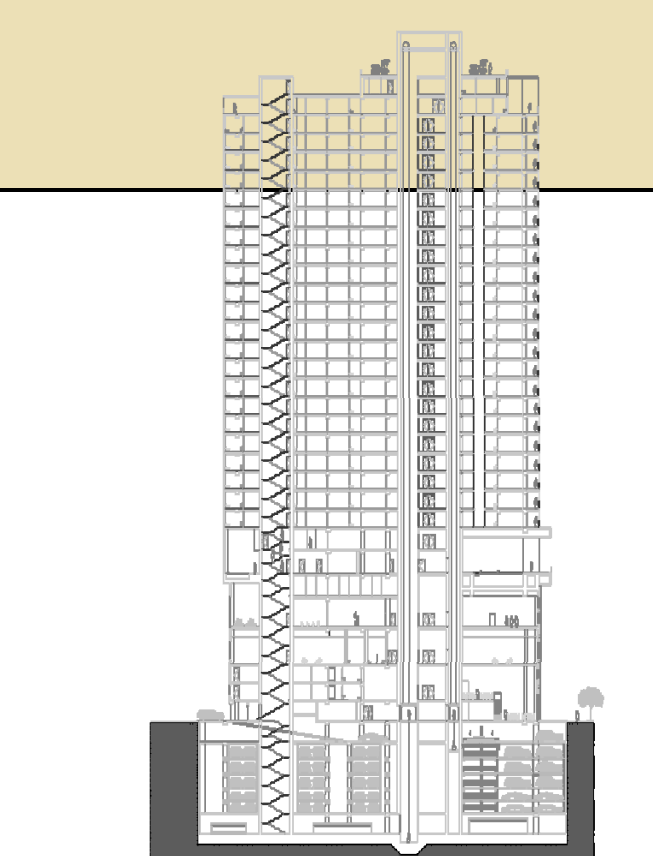
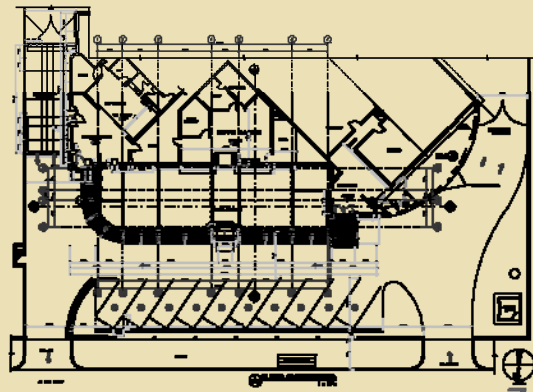

ARQUITECTOS-INGENIEROS-CONTRATISTAS

# SHERWIN WILLIAM

Location: Sarasota Avenue  
Santo Domingo

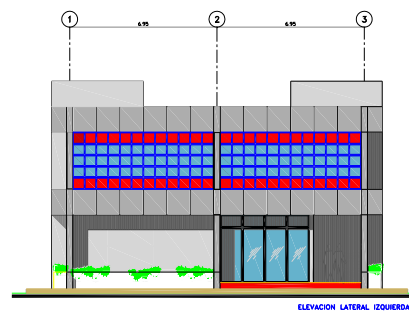
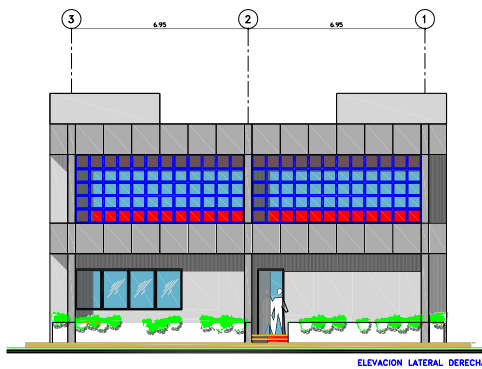
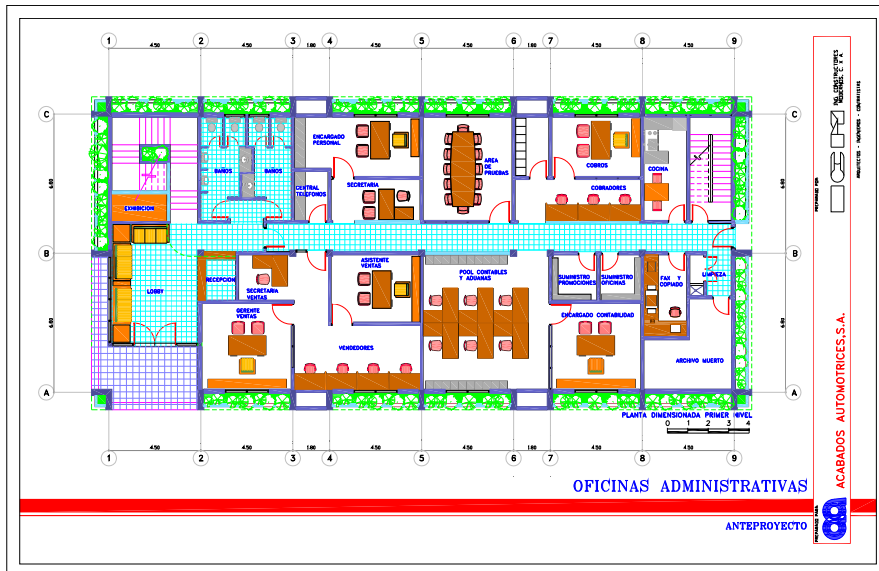

# AUTOBRITANICA

Location: John F. Kennedy Avenue  
Santo Domingo

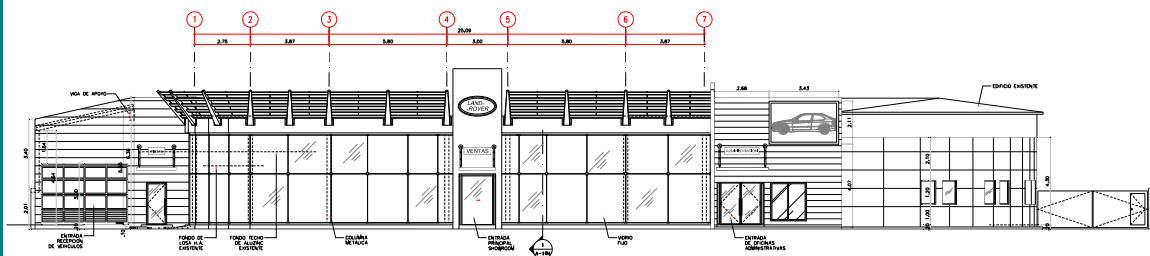
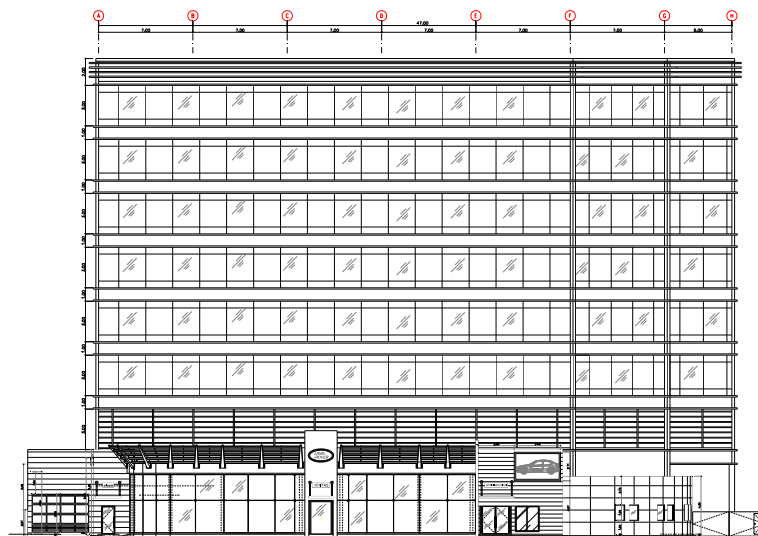
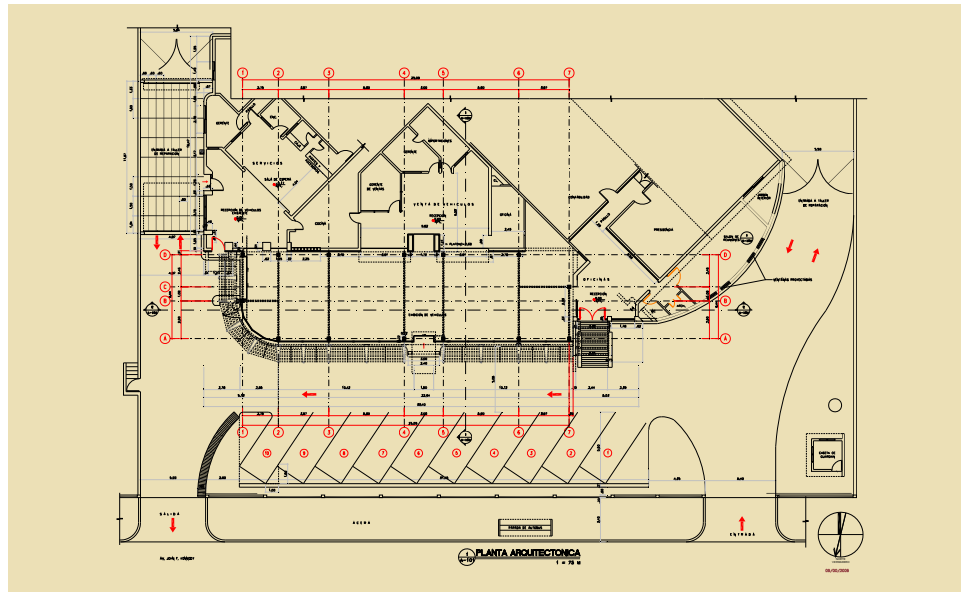

# Revs Performances Parts:

Location: John F. Kennedy Avenue  
Santo Domingo

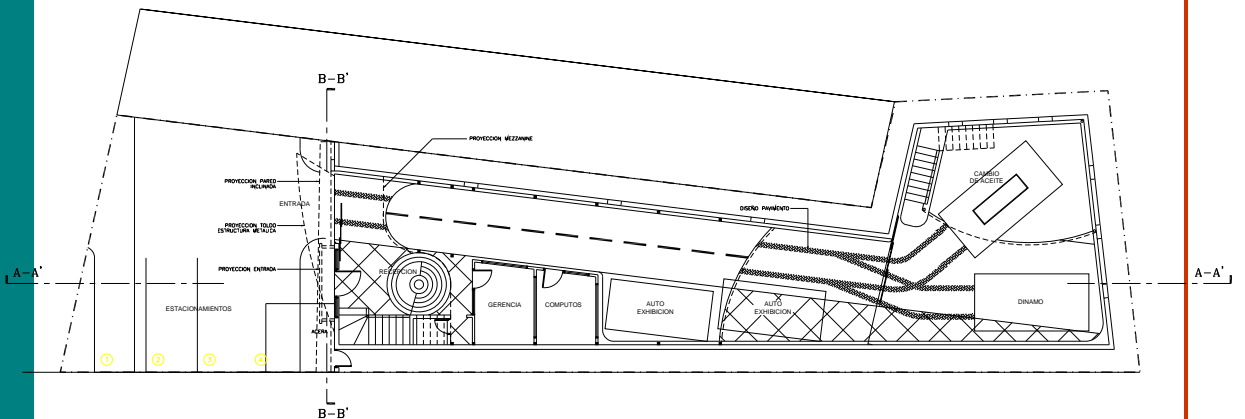
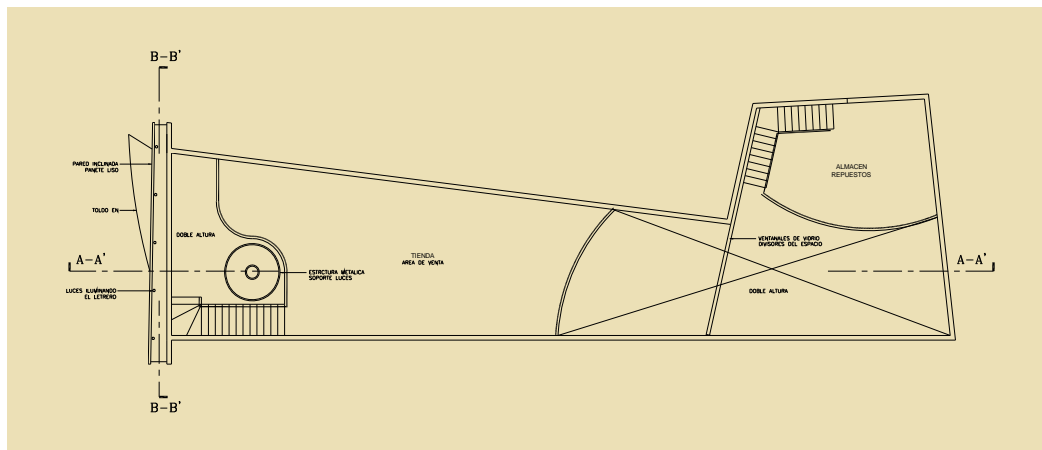
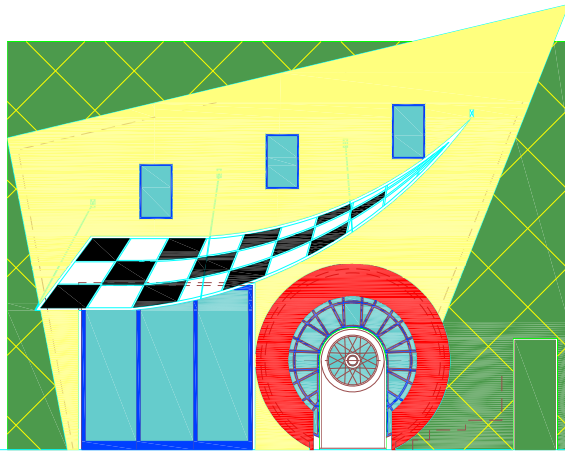



# Carib-Alico

Location: Lincoln Avenue  
Santo Domingo

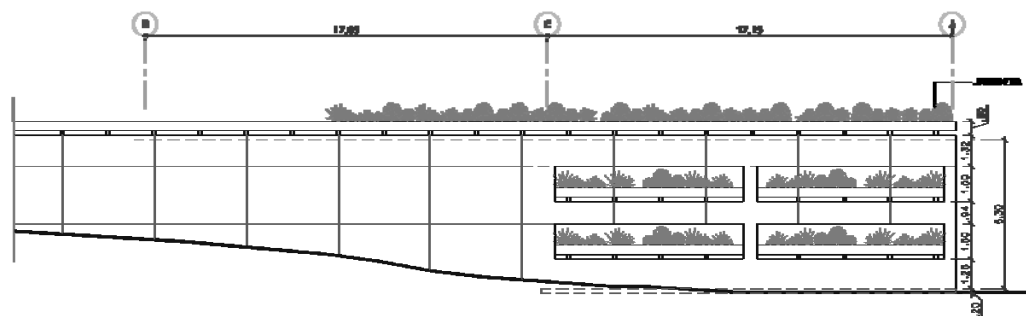
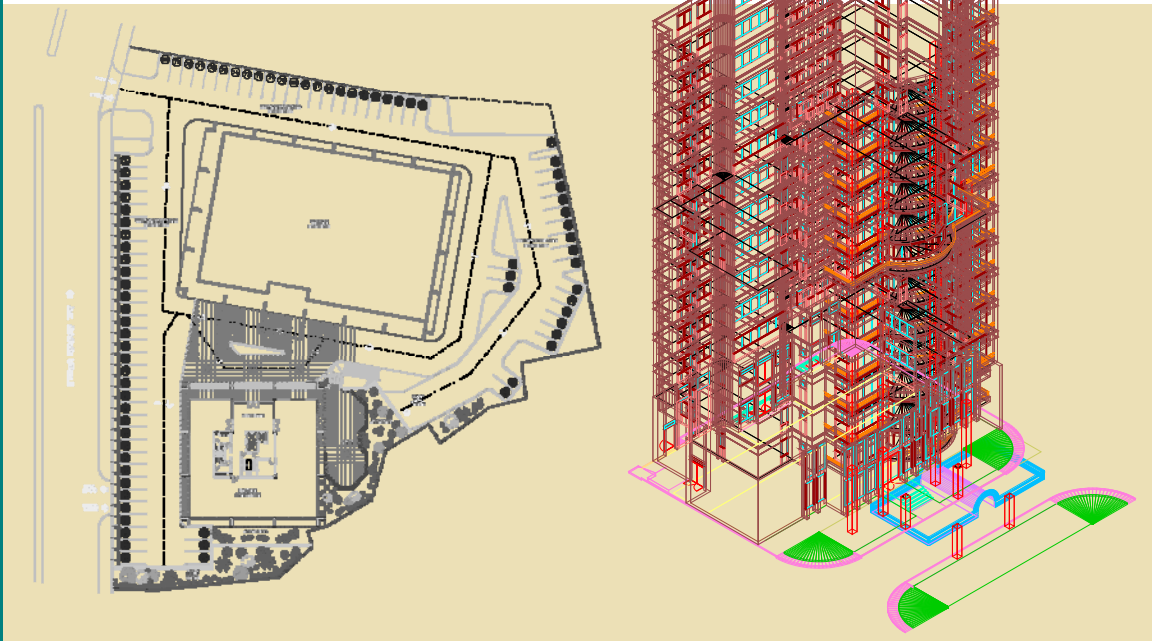

# La Despensa Supermarket

Location: Duarte Avenue  
Santo Domingo

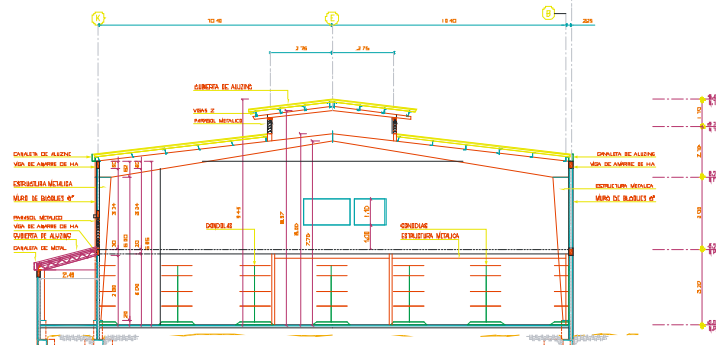
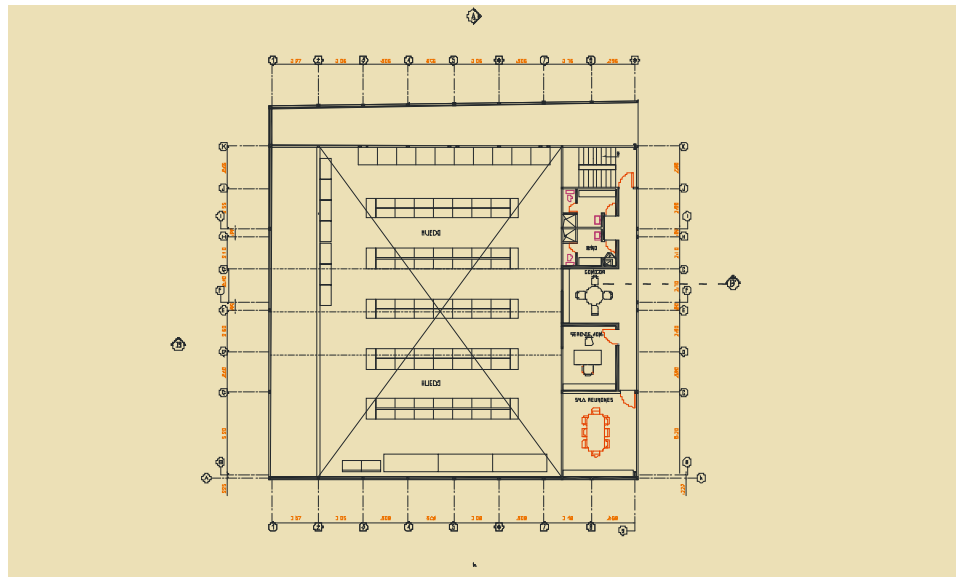

# La Despensa Supermarket

Location: Conde Santo Domingo

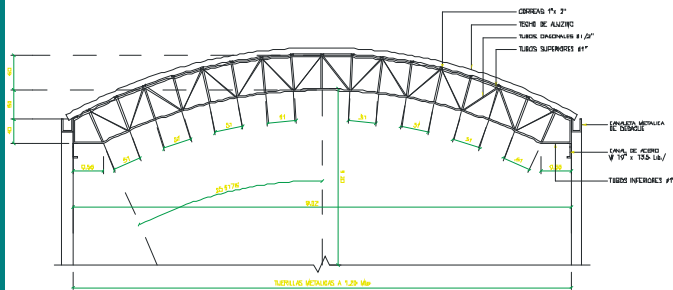
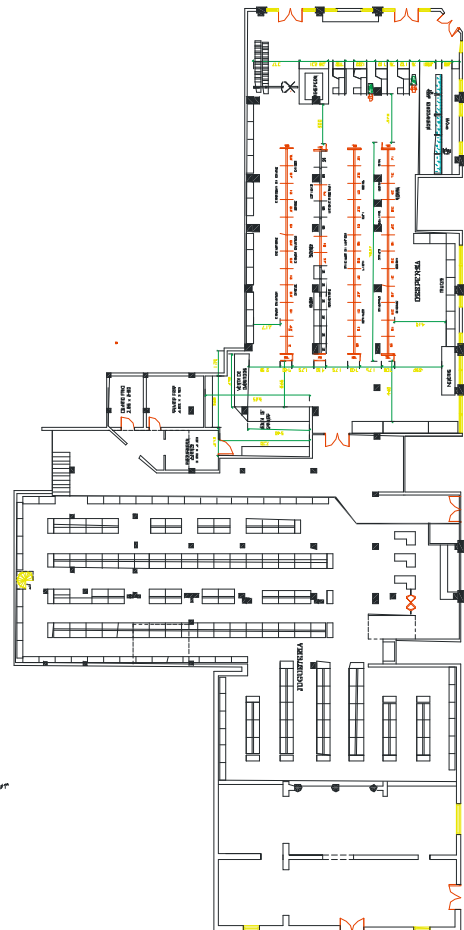
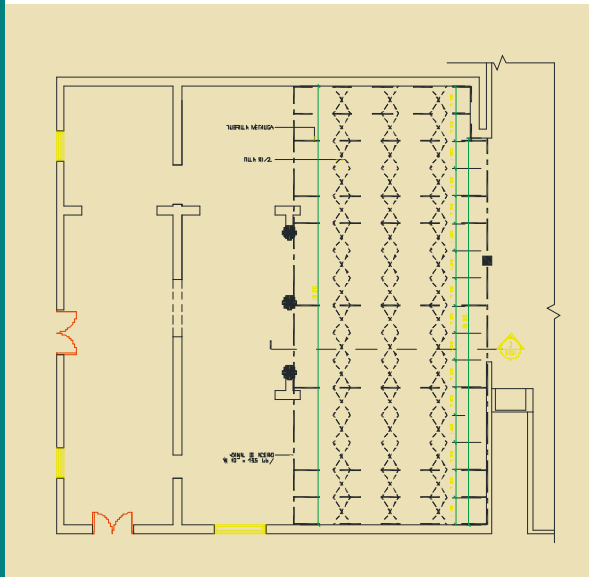

# La Despensa Supermarket

Location: Nicolas de Ovando Avenue  
Santo Domingo

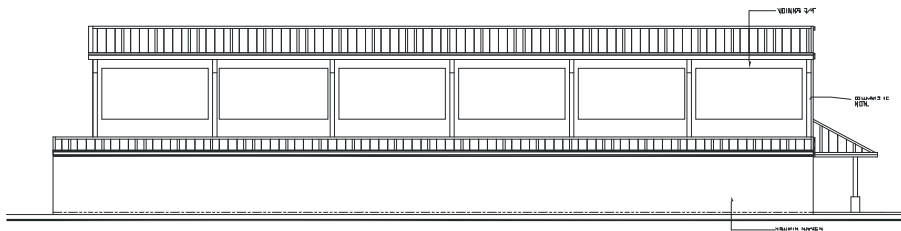
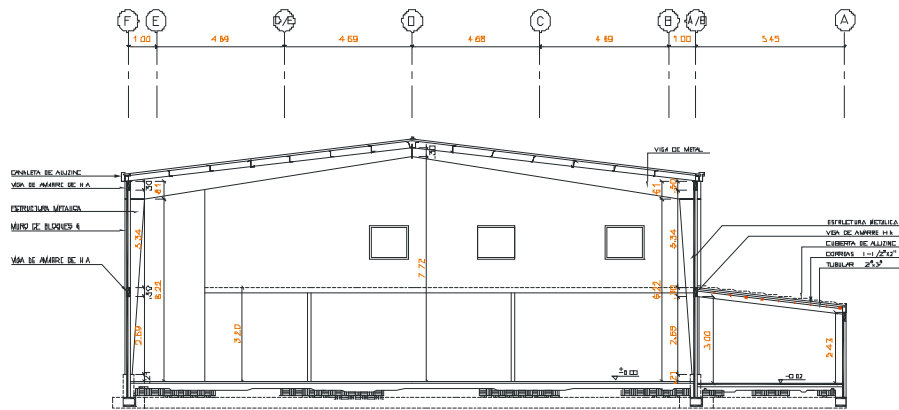
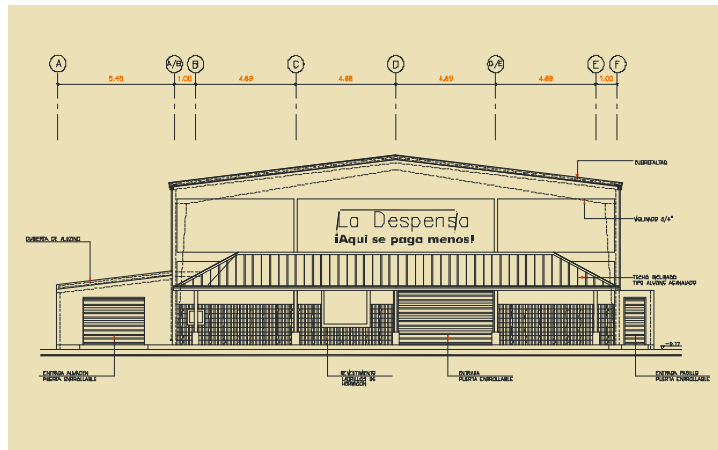
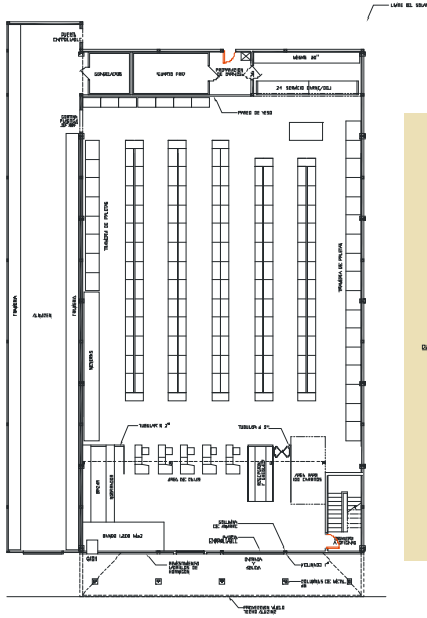

# La Despensa Supermarket

Location: Duarte Avenue  
Santo Domingo

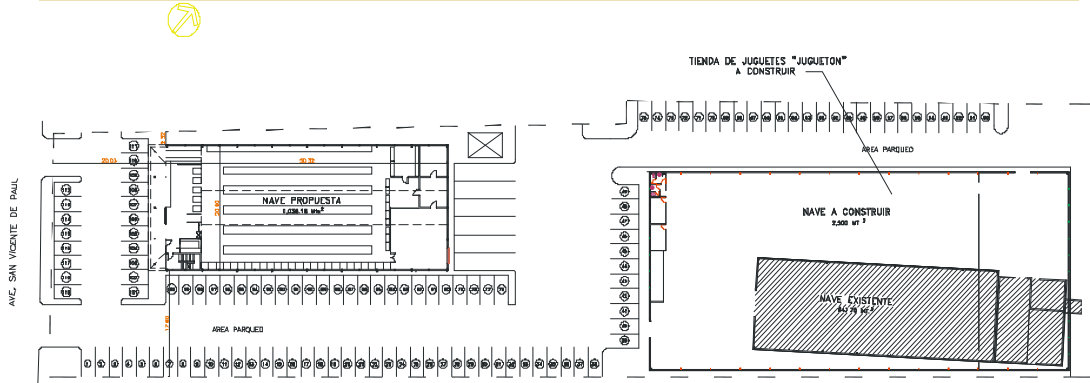
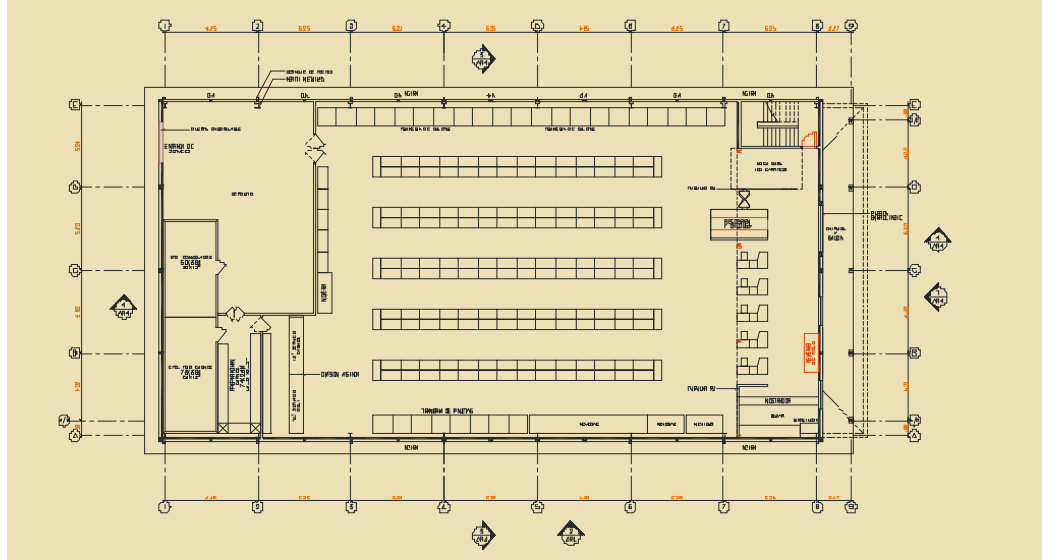
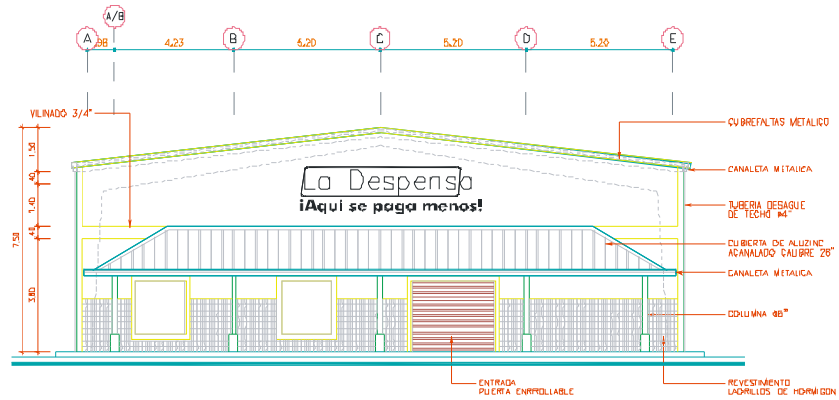

# Cuesta Nacional Center

Location: 27 Febrero Avenue  
Santo Domingo

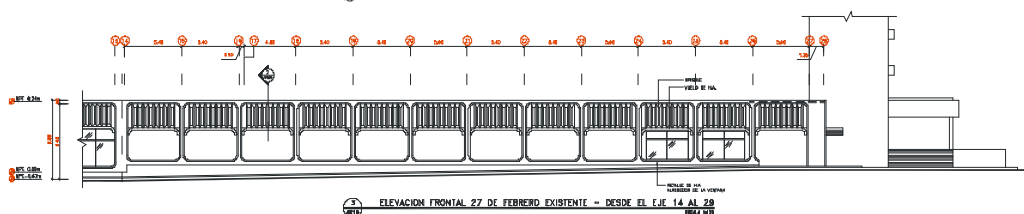
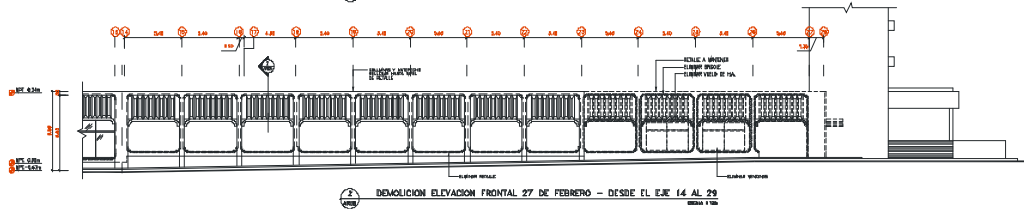
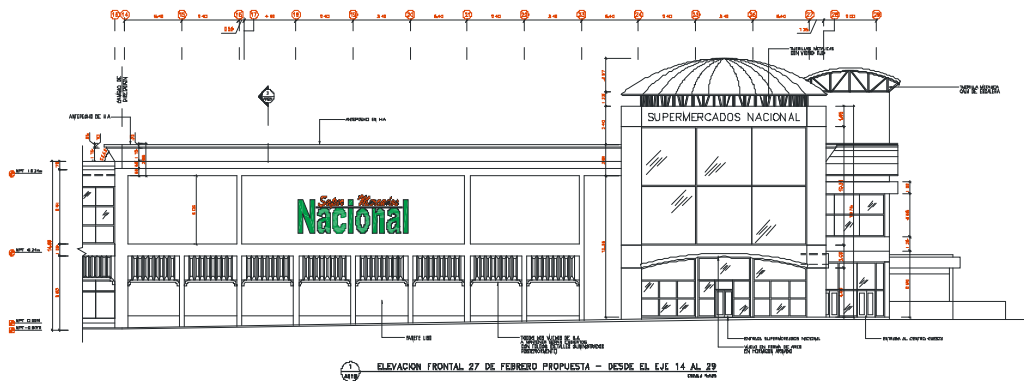
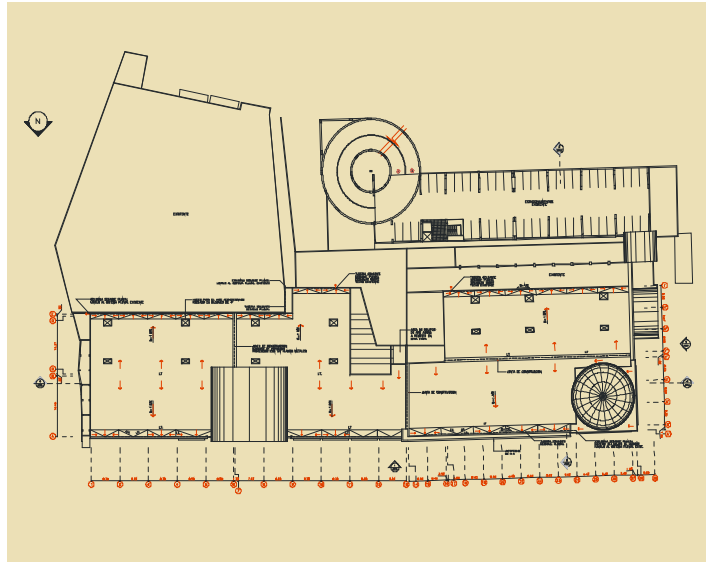
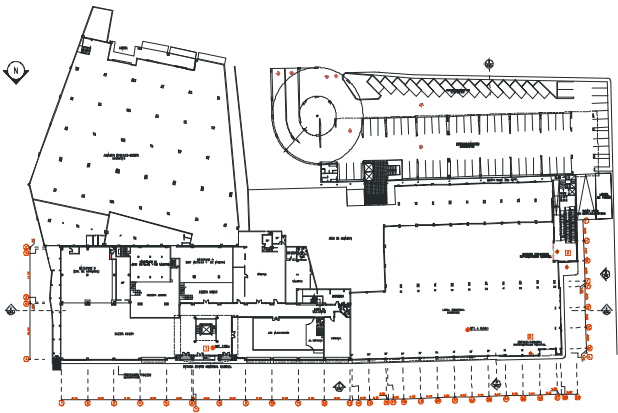

# Cuesta Nacional Center

Location: Charles de Gaulle Avenue  
Santo Domingo

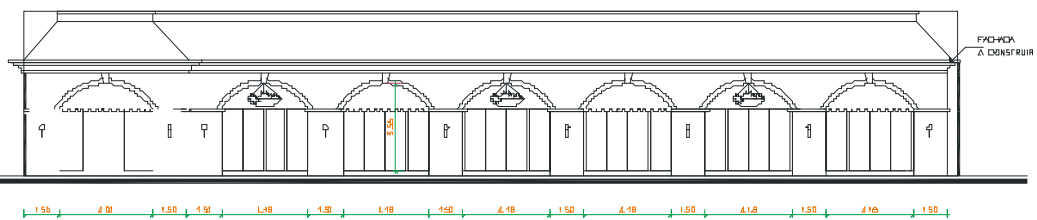
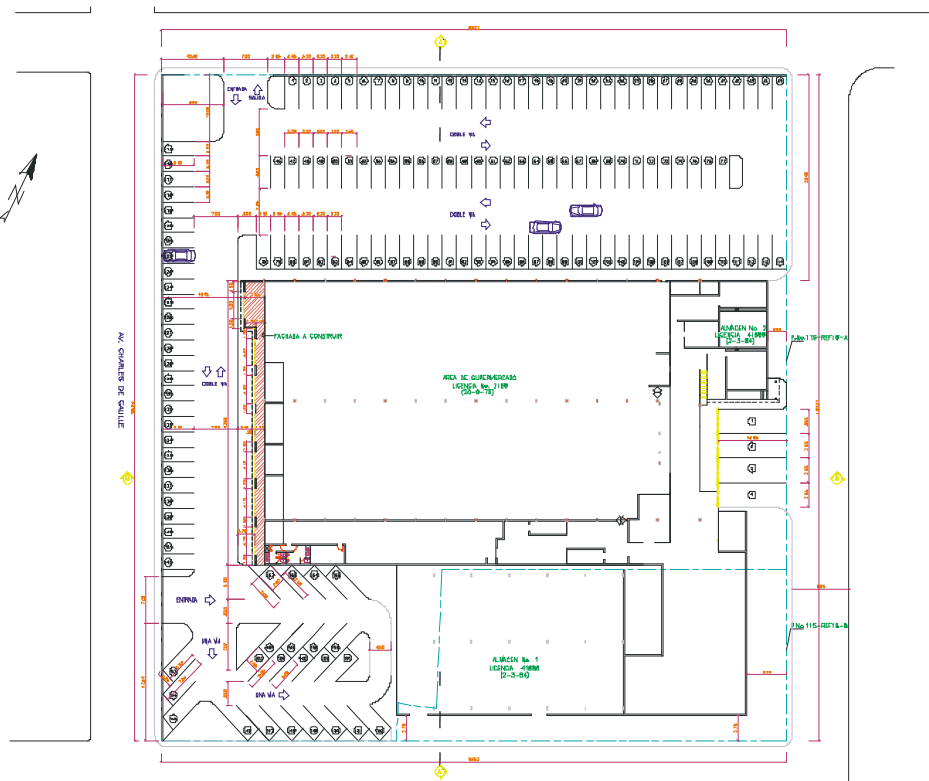

# Store of Toys Jugueton

Location: 27 de febrero Avenue  
Santiago

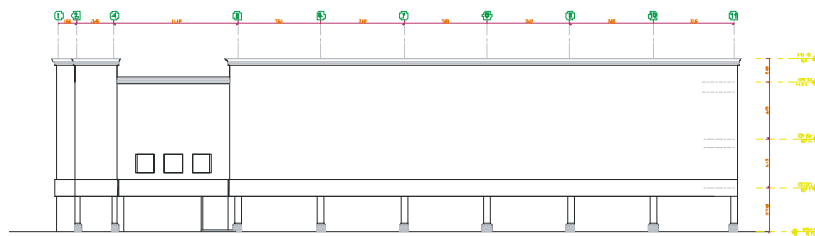
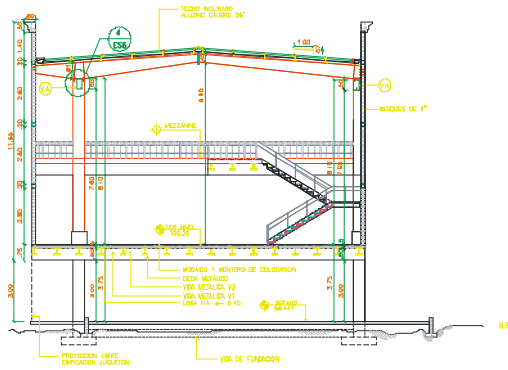
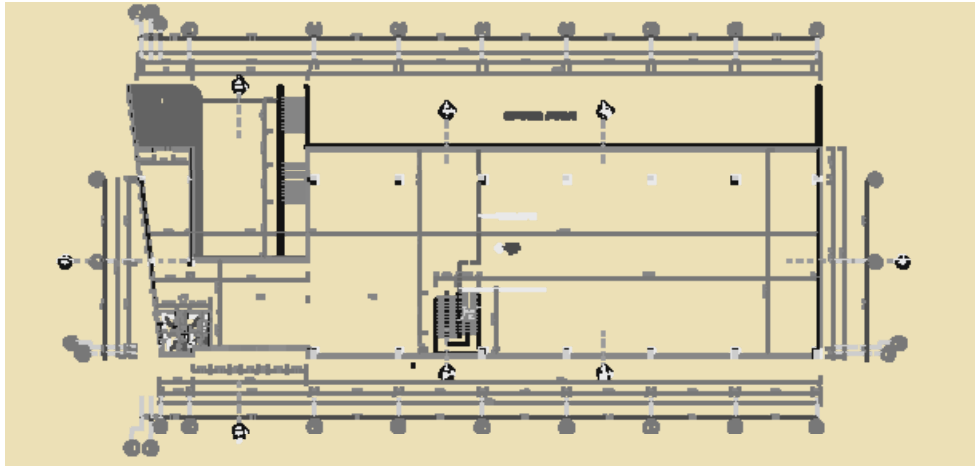

ELEVACION 200

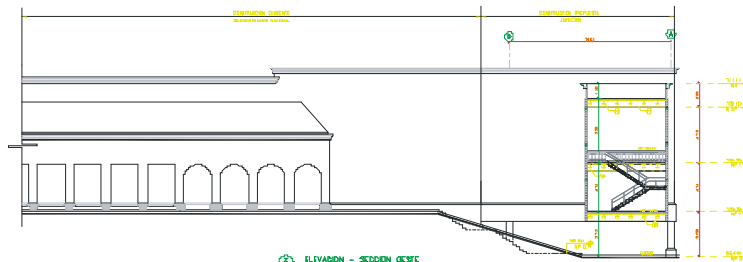

ELEVACION - SECCION 200



# Store of Toys Jugueton

Location: San Vicente de Paul Avenue  
 Santo Domingo

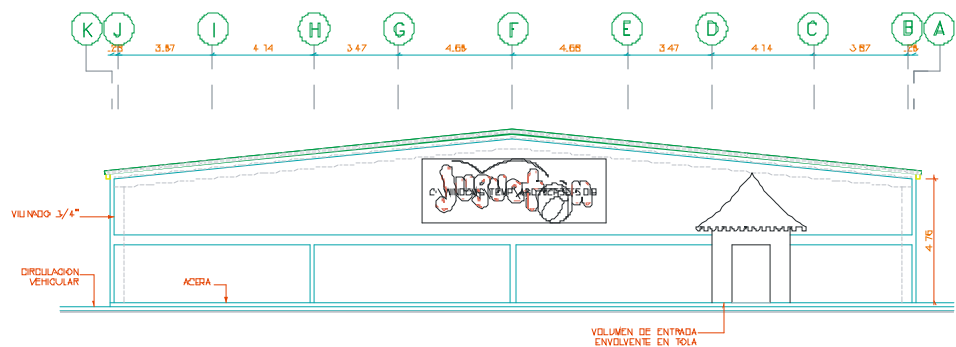
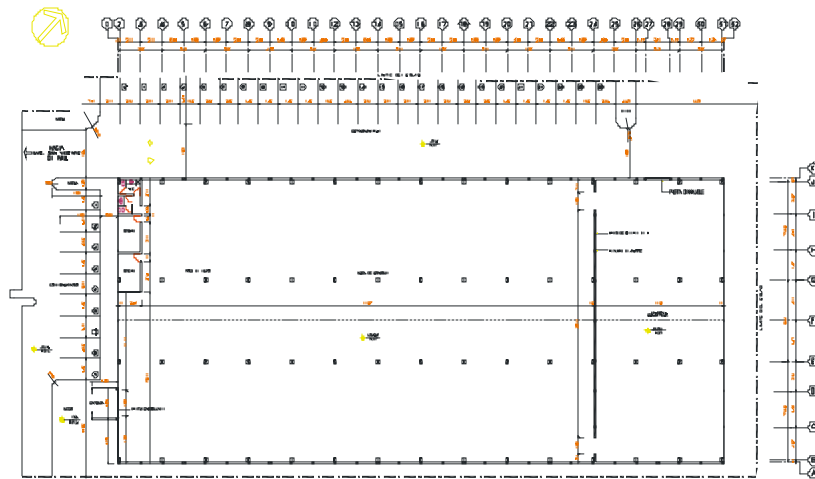
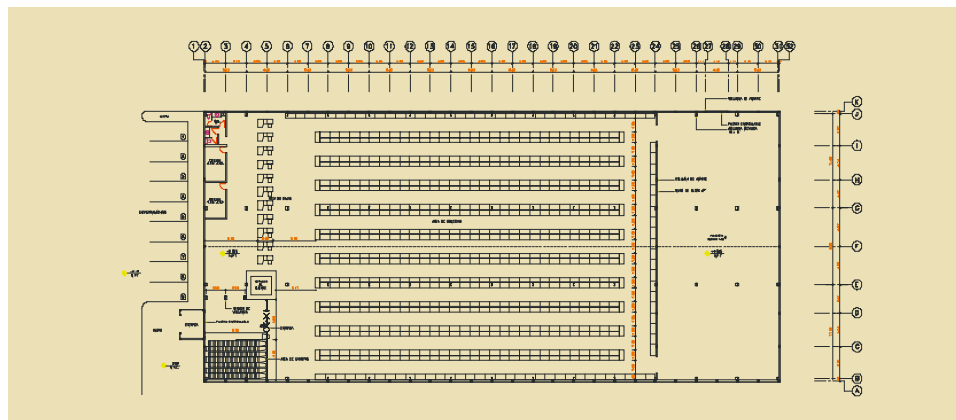

# Mega Centro Mall

Location: San Vicente de Paul Avenue  
Santo Domingo

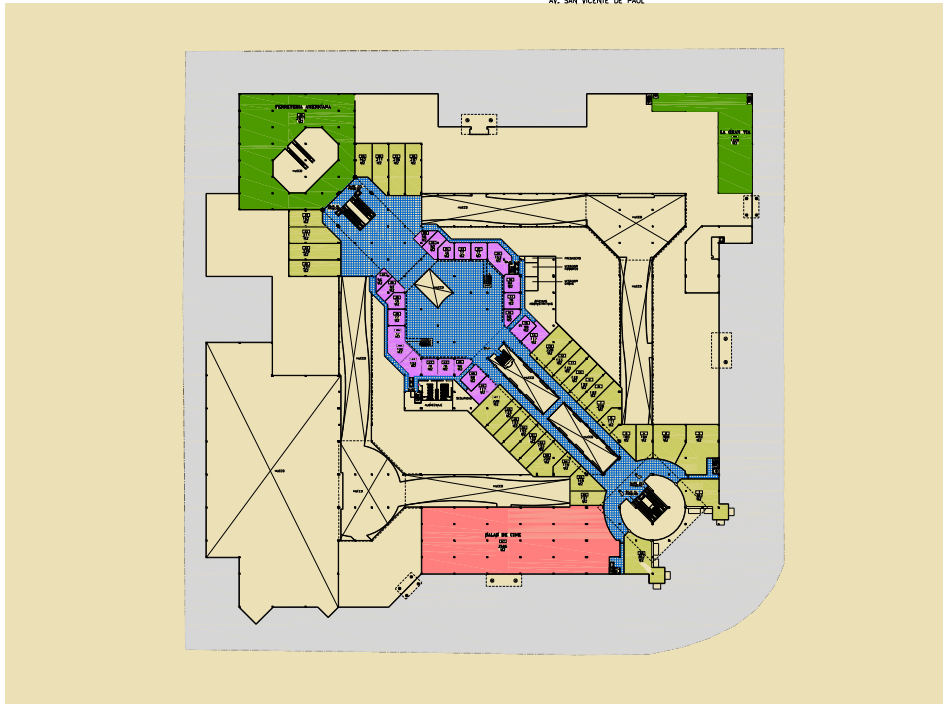

# Cars Showroom

Location: Bolivar Avenue  
 Santo Domingo

